

Boiler / Burner Efficiency Concerns

Excess Air

Linkageless Control

Air/Fuel Ratio Control (Oxygen Trim)

Presented by
Mark Evans
Blesi-Evans Company

Topics

- Excess air and how it affects efficiency of a boiler
- Linkageless controls
 - Benefits and cautions
- Methods of controlling excess air {Oxygen Trim}
 - Feedback and feed-forward
 - Benefits and cautions

Perfect Combustion Chemistry (natural gas)

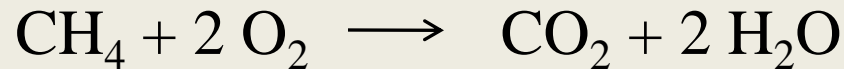
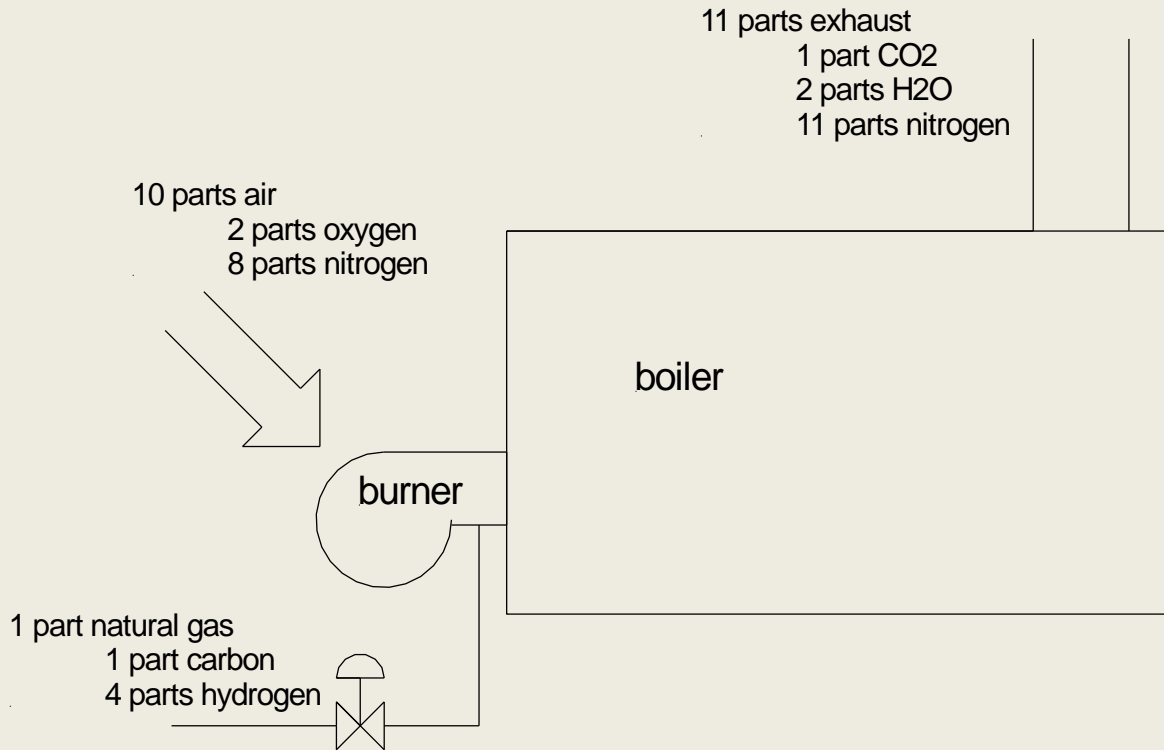

Perfect Combustion not Possible

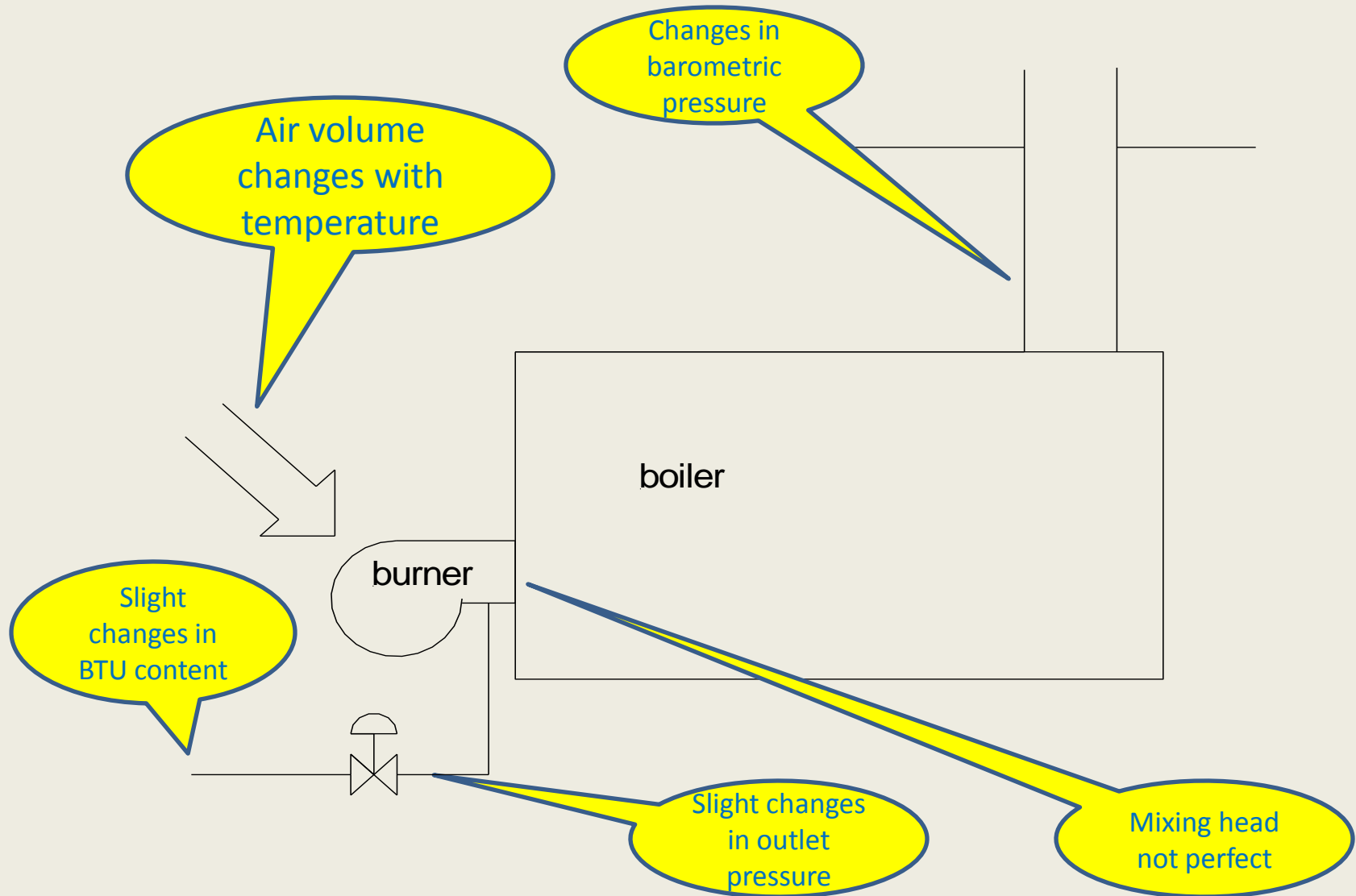

Not Enough Air?

- Unburned Fuel
 - a.k.a. carbon monoxide (CO)
 - Enough CO can cause an explosion
 - CO monoxide can kill people

Excess Air is Required

- GOOD news:
 - Air can be added over the amount needed for perfect combustion so that there is always more than enough
 - That air that is added is called *excess air*
- BAD news:
 - Every bit of excess air that is added detracts from the efficiency of the boiler

Excess Air

- Excess air is wasted heat
- Excess air is **NECESSARY** for safe combustion
- The more excess air there is, the more heat is wasted
- The less excess air there is, the more efficiently the boiler operates
- There is **NO TRADEOFF** between safety and energy conservation. **SAFETY RULES !**

Effect of Excess Air on Efficiency

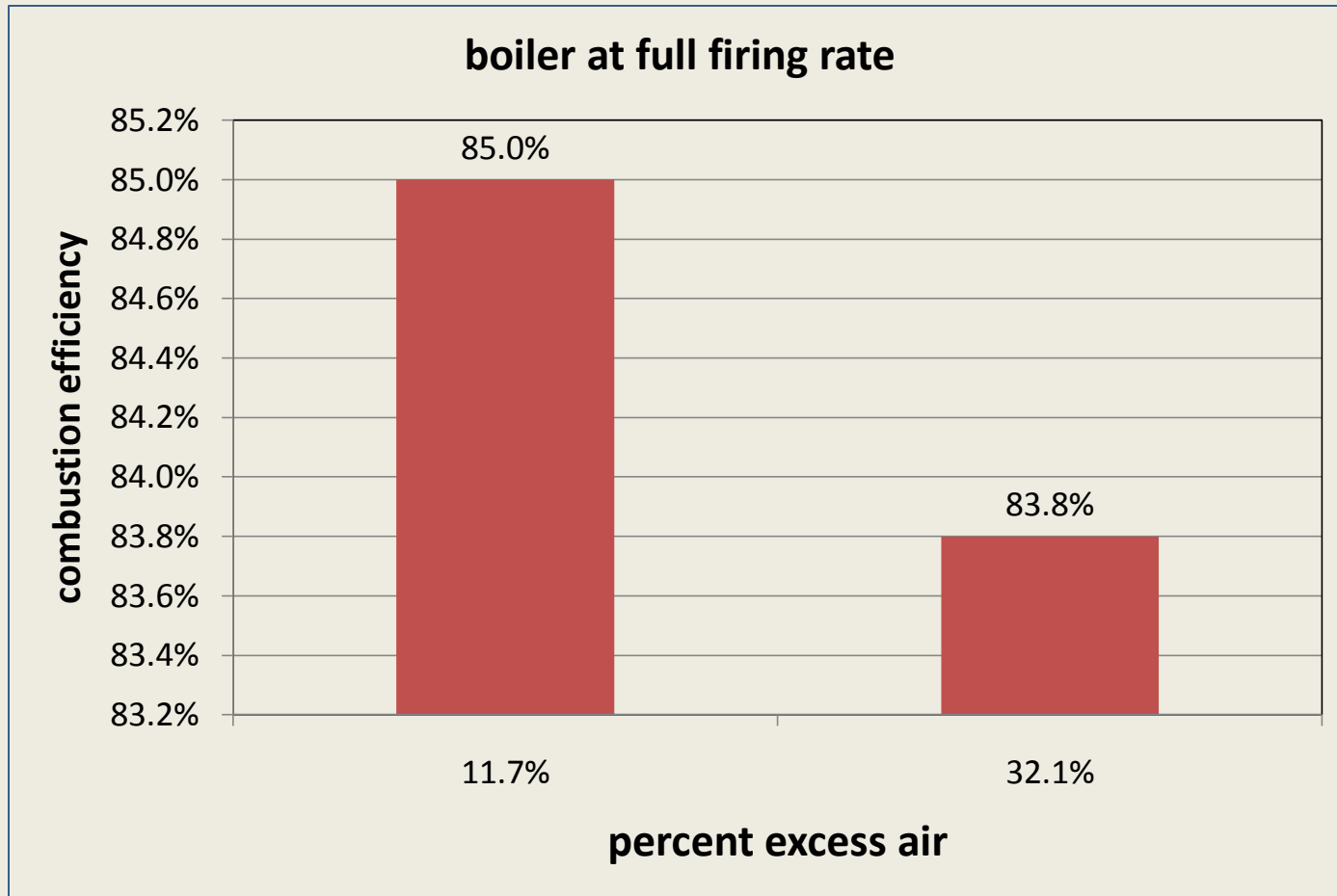

Effect of Excess Air on Efficiency

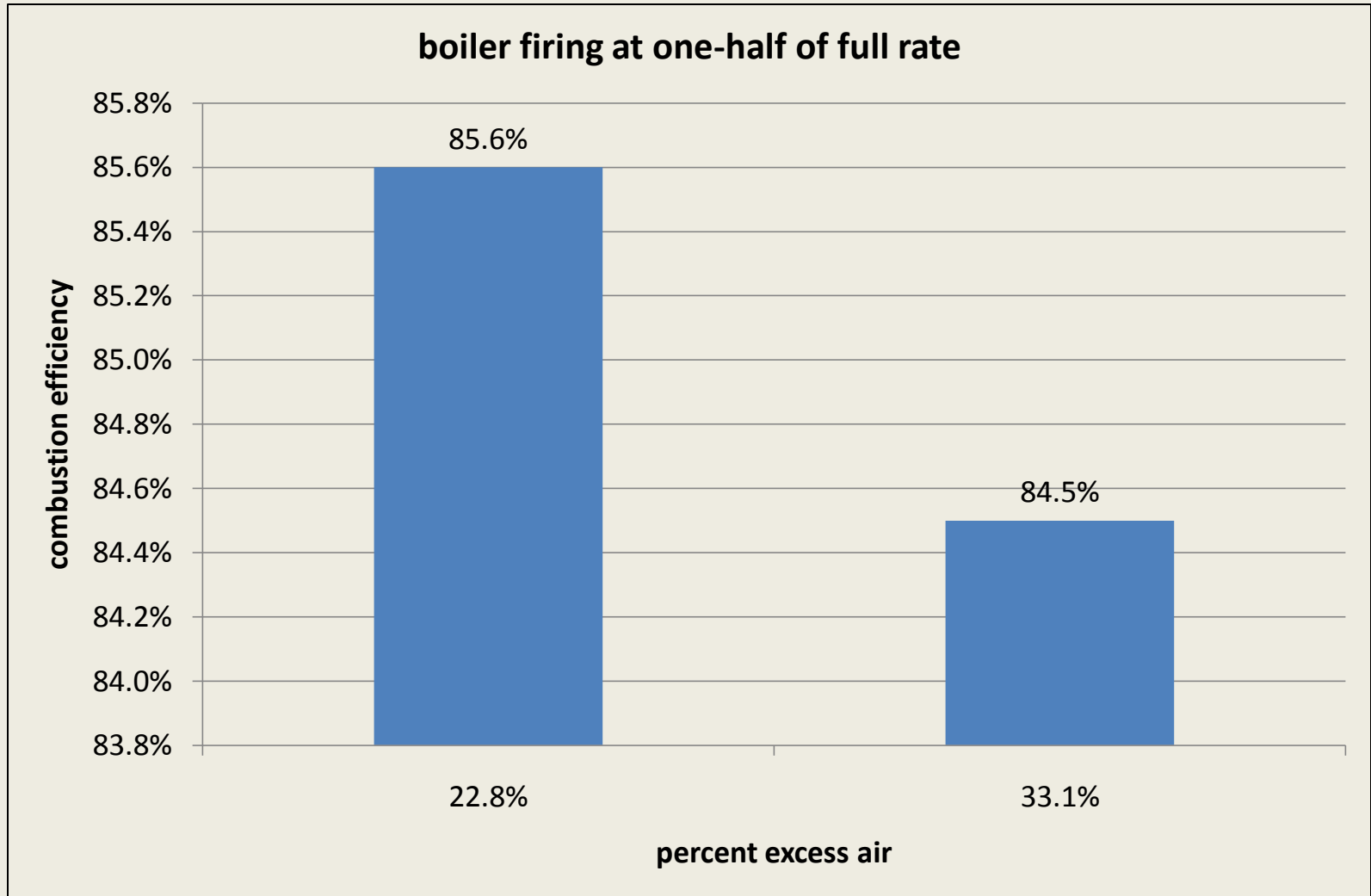

Excess Air vs. Efficiency

(from field testing on a boiler)

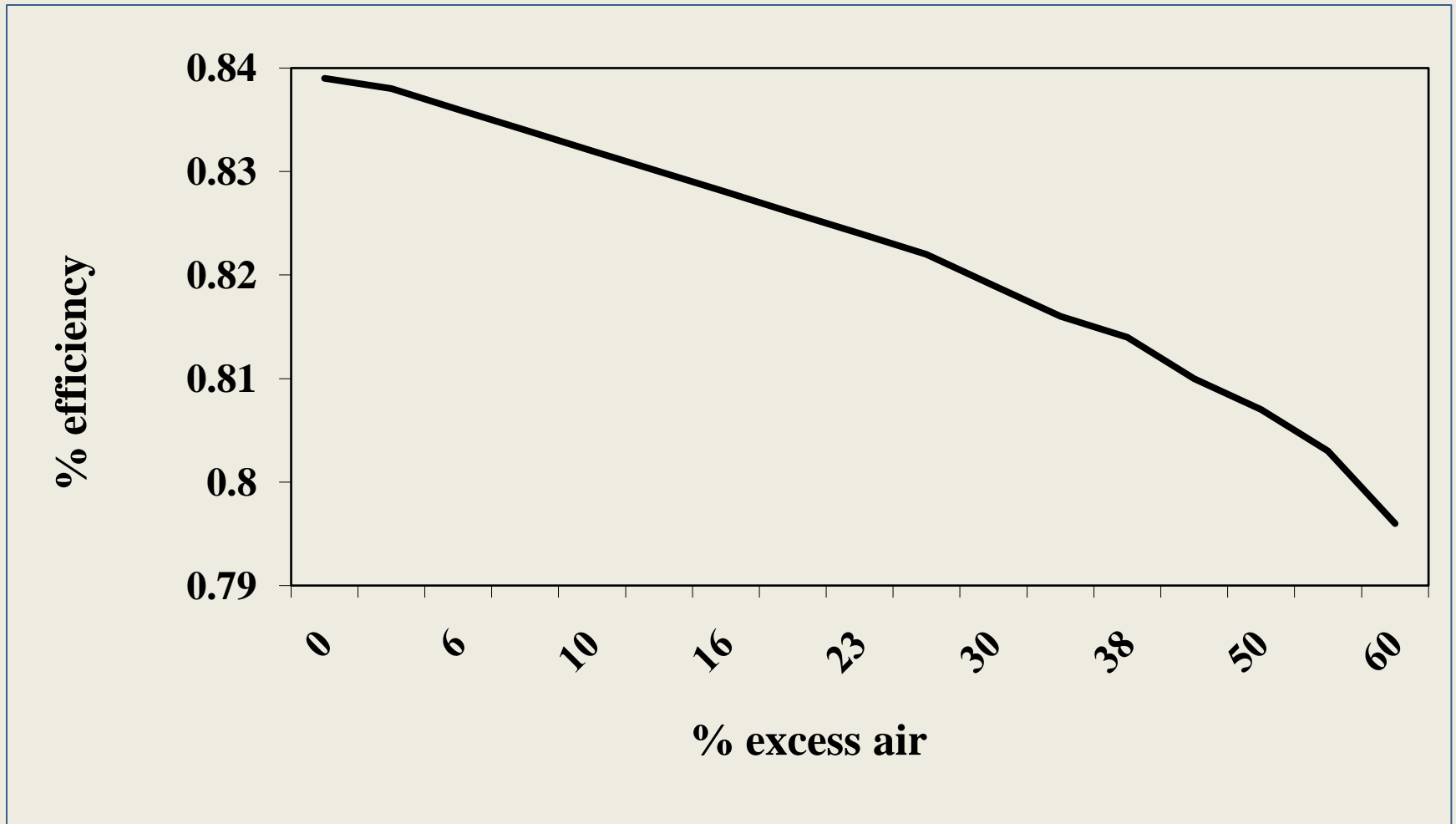

Cost of Excess Air

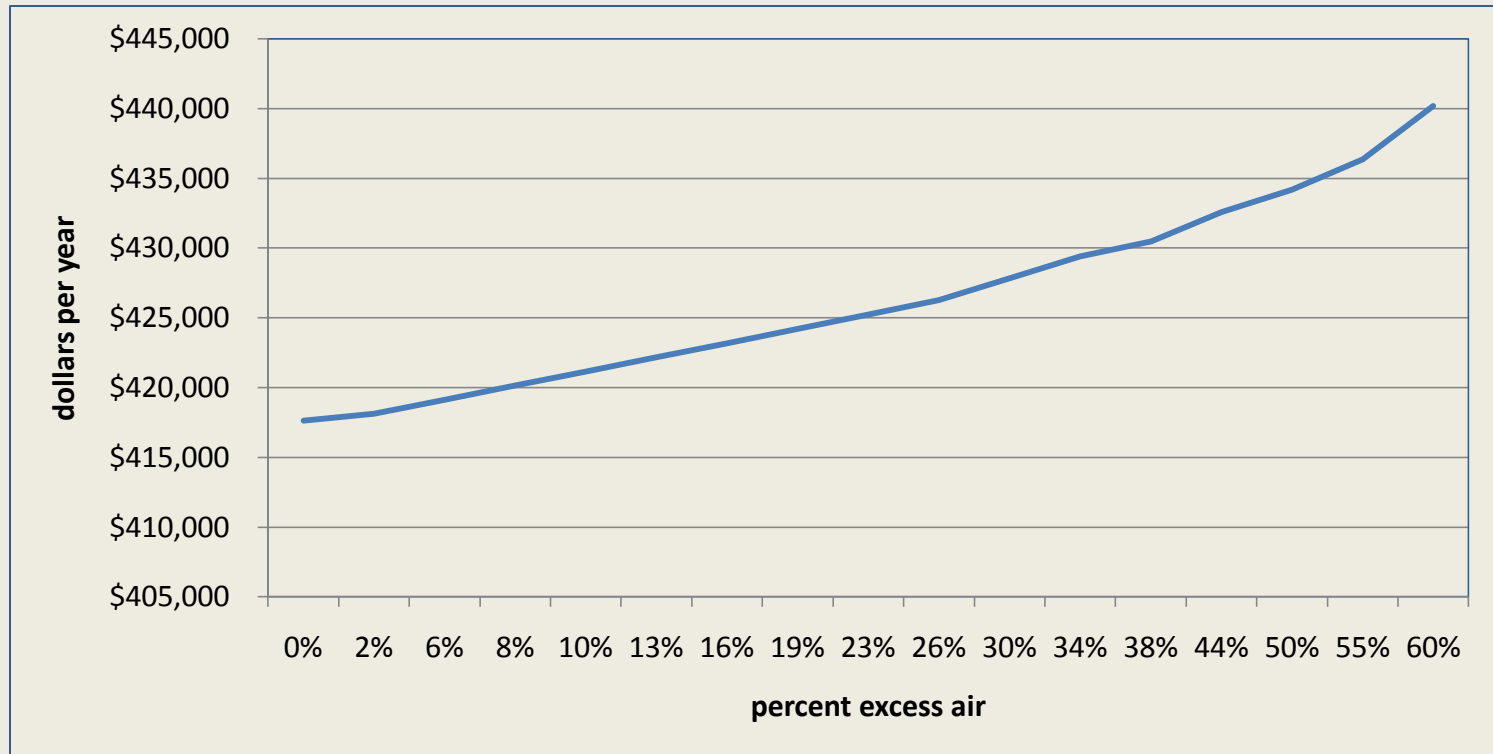

Constant load of 5,000 MBH and cost
of fuel at \$8.00 per million BTU's

Why do some burners need more wasteful excess air than others?

It is because of how they are made.

The design of the head dictates how much extra air is needed to achieve sufficient mixing of air and fuel to insure that all of the fuel is burned.

Head Design

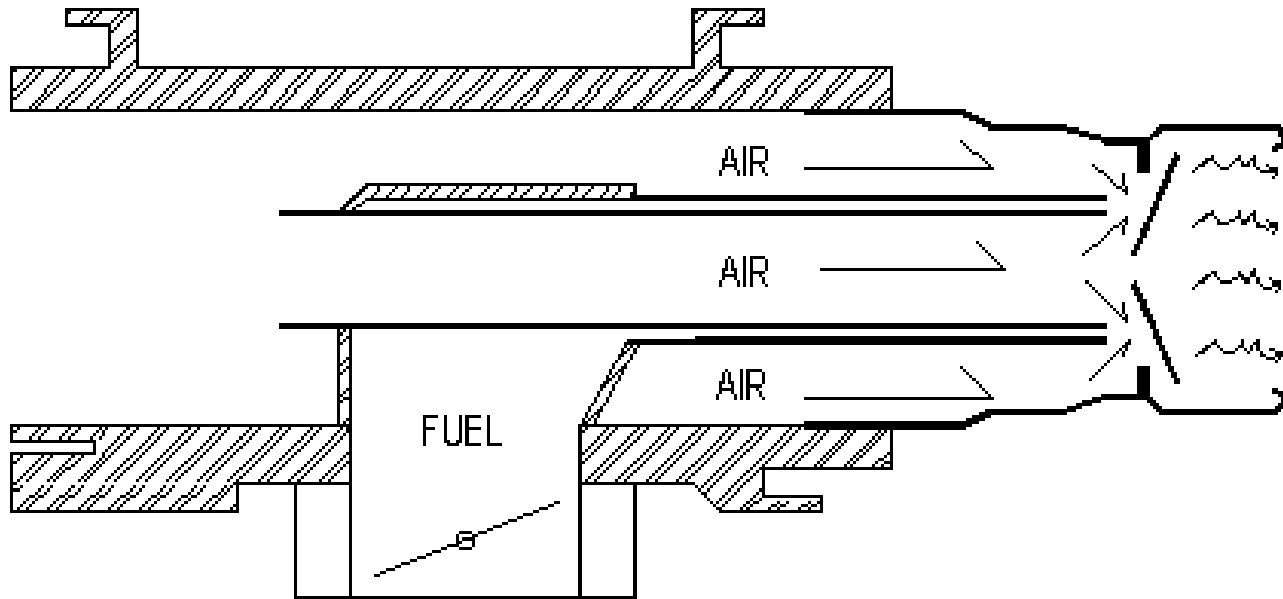

Burner head design dictates how well the fuel is mixed with air for complete combustion

Controlling Excess Air

- Linkage system
 - Single modulating motor
 - Linkage from motor to each driven device
 - Air damper, gas valve, oil valve, etc.
 - Modulating motor with cams
 - Linkage from motor to cam and cam to gas valve
 - Linkage from motor to cam and cam to oil valve
 - Allows for better tuning

Linkage/cam example

Cam

From modulating motor

Gas valve is fine tuned

Air damper

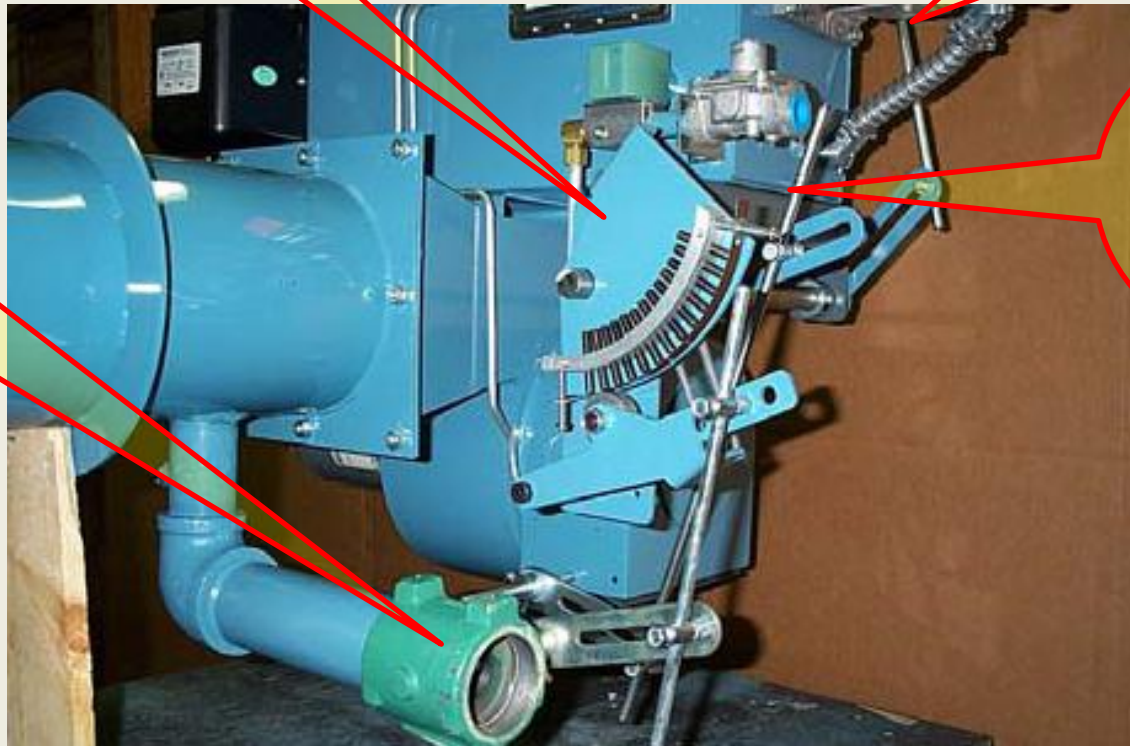

Source: Webster Engineering

Linkage hysteresis

- Due to design or wear
 - The position of a device is not the same when the modulating motor increases firing rate compared to when it lowers the firing rate.

Linkage hysteresis

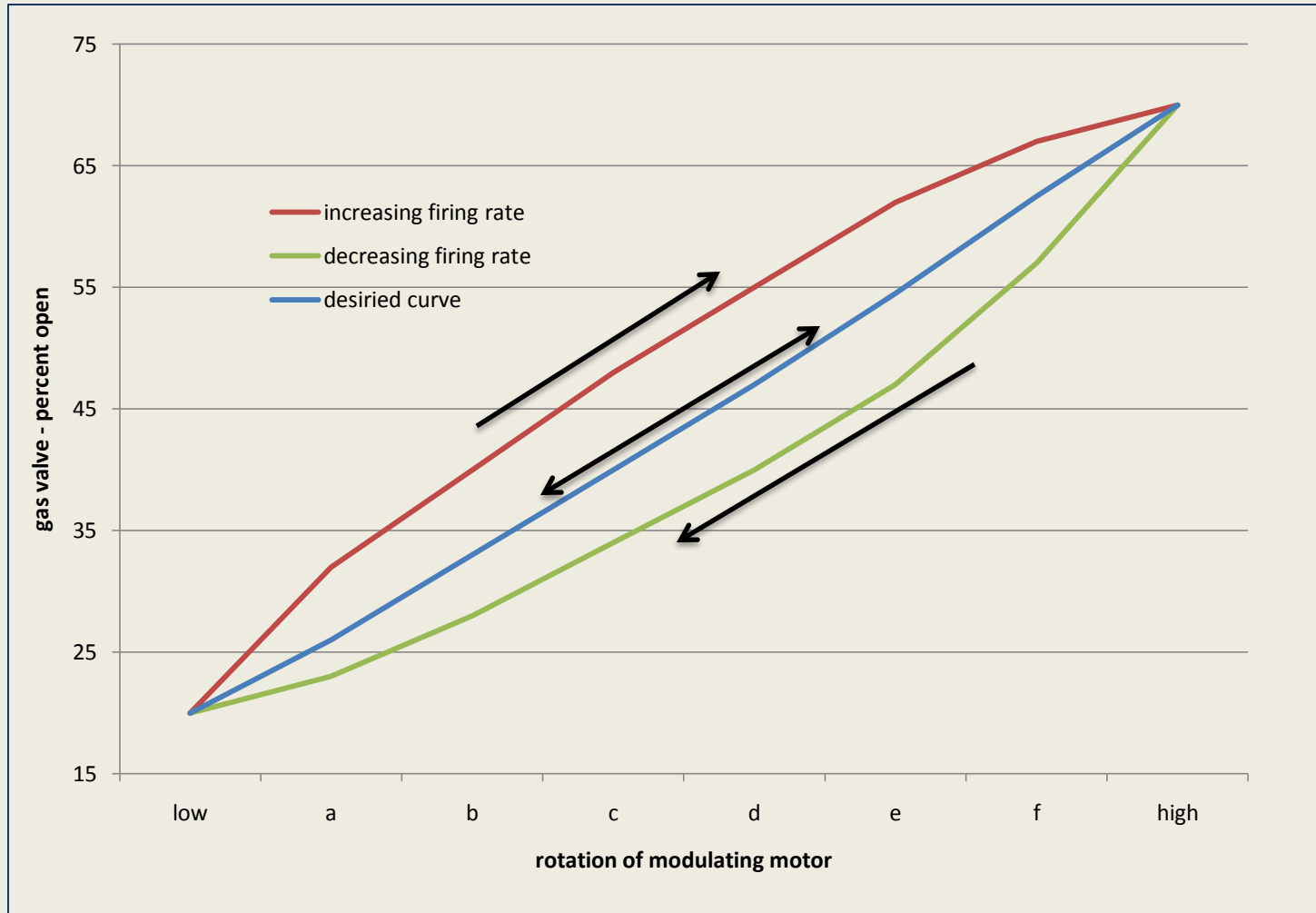

I - Linkageless controls

- Minimizes hysteresis
 - Separate servomotor on each rotating device
 - Gas valve
 - Air damper
 - Secondary air damper
 - Oil valve
 - VSD blower motor (not really a servomotor but....)
 - FGR damper

Performance

- Linkageless controls *DO NOT* make a poorly designed burner burn fuel better
- Linkageless controls *DO* allow a burner to burn fuel to the best of its ability

Guaranteed savings !

- Claims of **10% minimum** have been made
- Payback forms provided by some manufacturers
 - **Assumed** savings of 2 or 3 percent just taken for granted

Is that rational?

Possible Energy Savings

- Higher turndown
 - If a burner's turndown performance on natural gas is limited by its ability to burn oil
 - retrofit makes good sense in this case
 - Amount of savings?
 - Our boiler/burner operation software predicts 1% to 2% savings when changing from 2:1 turndown to 3:1
 - If burner is designed for high turndown
 - Linkageless is almost a must because of hysteresis in most linkage designs

Possible Energy Savings

- Better burner air/fuel ratios
 - The set up involves programming several points along the firing rate curve
 - It has to be done well
 - Removes hysteresis
 - How do you quantify that?

II - Air/Fuel Ratio Trim (O₂ Trim)

- The air/fuel ratio is maintained at a constant level (by changing air damper position)
 - Adjusts for combustion air density (temperature)
 - Adjusts for stack performance changes
 - Barometric pressure
 - Adjusts for gas pressure variances
 - Adjusts for BTU value of gas
 - Perhaps CenterPoint is perfect 😊

One Way it is Done

- Feedback method
 - The content of oxygen in the flue gas is measured
 - Converted to an analog value
 - Air damper (normally) position is changed so that the set point is maintained
- Advantage:
 - Accounts for all of the variables that can cause a change in air/fuel ratio
- Disadvantage
 - Can be troublesome

How Well it Works

% oxygen	combustion efficiency
1.5	84.5%
2	84.3%
2.5	84.0%
3	83.8%
3.5	83.6%
4	83.5%
4.5	83.1%
5	82.8%
5.5	82.6%
6	82.2%

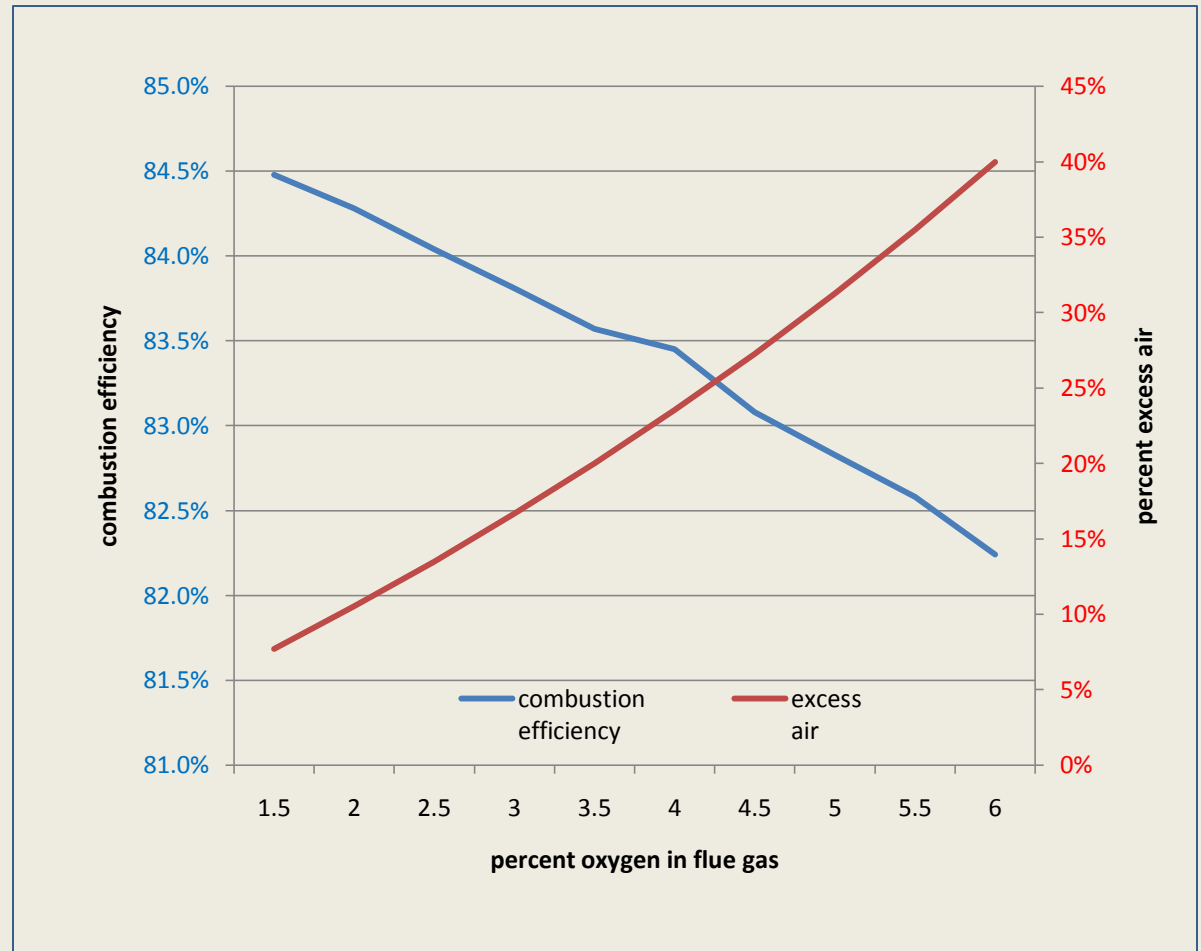

Payback Period

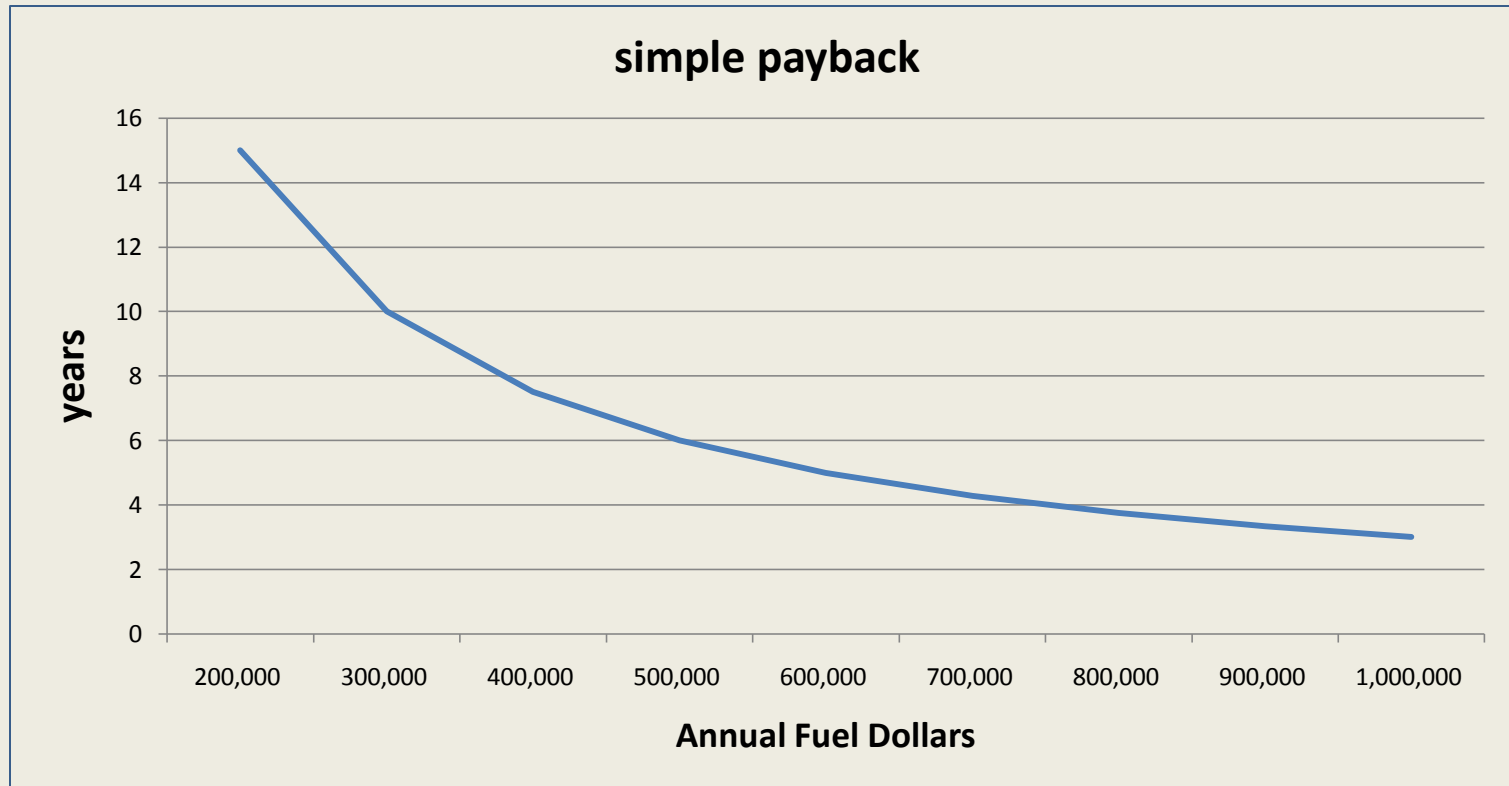

Based on savings of 1% of fuel bill
and \$30,000 installed cost

Troublesome?

- Ask vendor for a list of references
 - Some brands better than others
- How long does the oxygen sensor last?
 - How much does it cost to replace it?
- Do the electronics account for how long it takes for the gasses to go through the boiler?
 - If not, there can be wild swings and awful combustion at lower firing rates
 - Some systems calculate that during set up

Another Way it is Done

- Feed-forward method
 - Air temperature is measured (the biggest factor)
 - Fan speed adjusted by VSD to maintain constant mass flow of air (a fan moves “constant volume”)
- Advantage
 - Air density is the most variable of all the factors that can change the air/fuel ratio
 - Less expensive than Feedback type control
- Disadvantage
 - Less energy recovery

Effect of Temperature

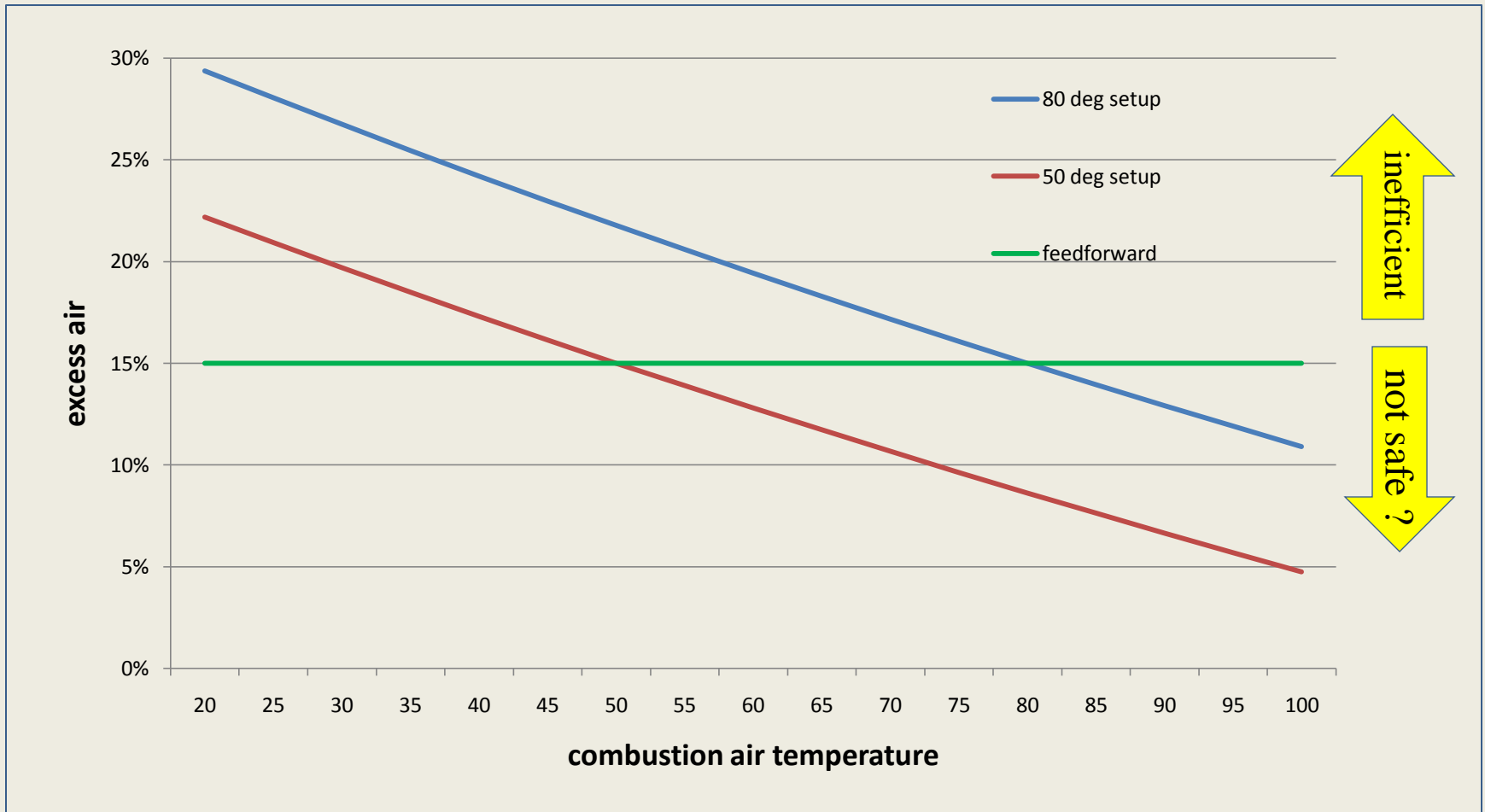

Is Combustion Air Temperature Constant?

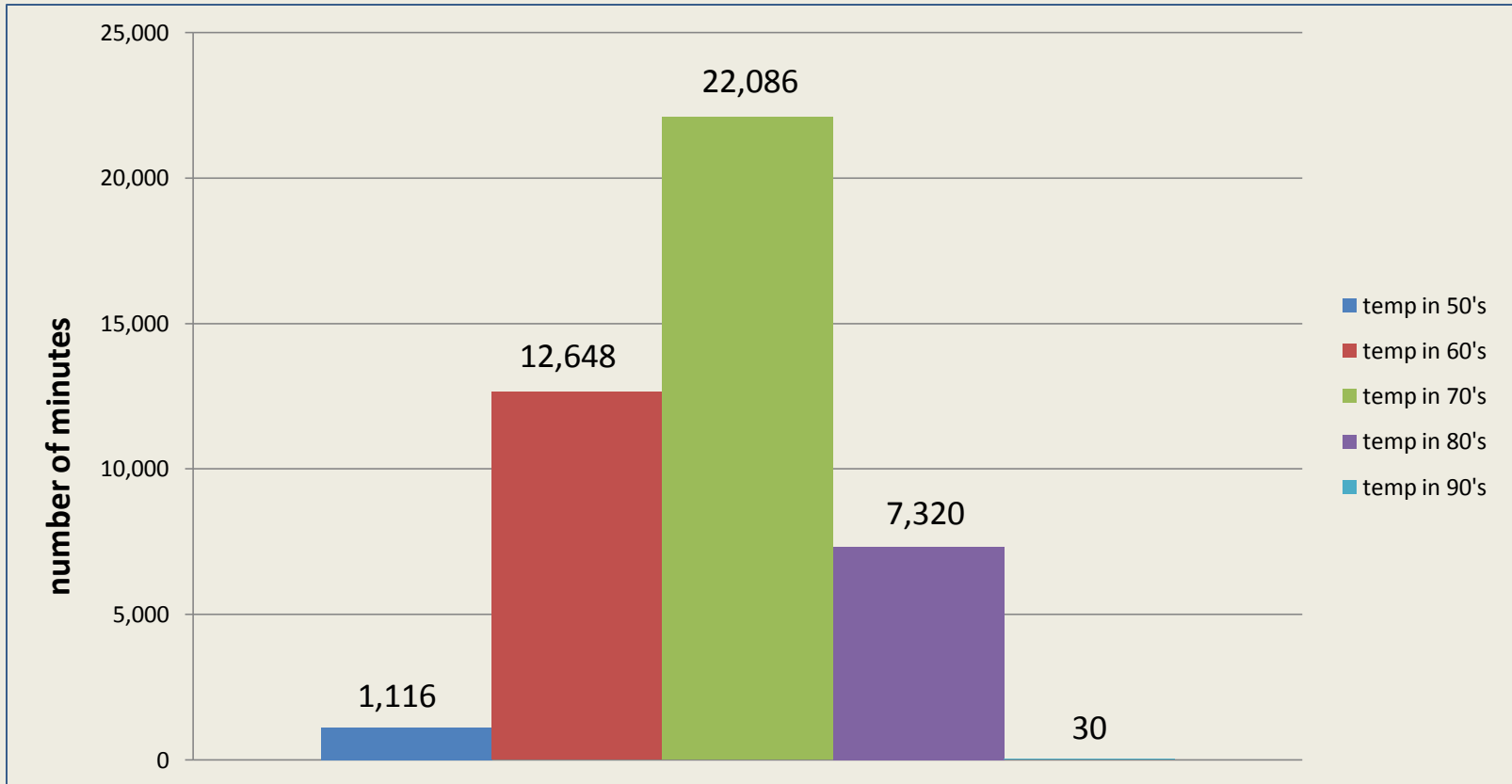

Sept 2009 in industrial plant's boiler room

Questions?

Contact information:

Mark Evans

Blesi-Evans Co.

Phone (612) 721-6237

Fax (612) 721-7466

Cell (612) 702-4871