



MORE COMFORT
LESS ENERGY

For more information about efficient natural gas
or energy-saving programs and services,
visit our Web site at CenterPointEnergy.com
or call 612-372-4727 (1-800-245-2377.)



Always There.®

Your guide to energy savings
and year-round comfort from
the experts



Always There.®

**MORE COMFORT,
LESS ENERGY**



Always There.®

TABLE OF CONTENTS

Introduction	1
1. Dialing down and dressing up	5
Dialing down your thermostat	5
Programmable/setback thermostat	5
Recommended thermostat settings	6
Exceptions to recommended thermostat settings	6
Keep warm in winter and cool in summer	7
How to stay warm	7
How to stay cool	8
2. Sealing your home	10
Why sealing your home can save you money	10
Sealing the attic	11
Sealing doors	13
Weatherstripping doors	13
How to weatherstrip a door with vinyl V-strip	14
Doorsweeps	15
How to put on a metal doorsweep	16
Caulking doors	18
Other ideas for doors	18
Sealing windows	19
Using caulk to seal windows and window frames	20
Weatherstripping windows	20
How to weatherstrip a double hung window with vinyl V-strip	21
Using window coverings to help seal windows	23
Other ideas for windows	24
Sealing the basement	25
Sealing other areas on the inside of your home	26
Sealing the outside of your home	28
Caulk and other sealing materials	29
Caulk	29
Types of caulk	29
How to caulk with a caulk gun	31
Other materials for sealing	33
3. Appliances	35
Heating system	35
Cooling system	36
Water heater and hot water pipes	37
Kitchen range	40
Range top	40
Oven	41
Clothes washer	42
Clothes dryer	42
Refrigerator/freezer	43
Dishwasher	45
Other energy users in your home	46
4. Natural gas: the premium fuel	48
5. For more information	49

INTRODUCTION

Stay warm, keep cool and save money

By using the ideas in this book, you can increase the seasonal comfort of your home while improving energy efficiency. The book shows you how to make your home warmer in winter and cooler in summer and how to cut the amount of money you spend on energy. Most of the ideas in this book will cost you very little; many of them are free.

The book is divided into five parts. The first part shows you how to dial down your thermostat and make yourself comfortable; the second shows you how to seal your home from the inside for greater energy efficiency; the third shows you how to save energy by using your appliances wisely. Part four provides general information about natural gas. You can turn to section five to find out how to contact us.



How to use this book

1. Scan through the book to familiarize yourself with the variety of information it contains.
2. Use the information in the first part of the book to dial down your thermostat and make yourself more comfortable.
3. Follow the step-by-step instructions for sealing the various parts of your home. Always begin in the attic or upper level. Each crack or gap you seal will save energy.
NOTE: Before you begin to seal, read the section called "Caulk and other sealing materials" (pages 29-34). Be sure to read all the step-by-step instructions for any task before starting. If step-by-step instructions are not given for a task you need to do, call CenterPoint Energy (see page 50).
4. Use the last part of the book as a handy reference for ways to save energy on your home appliances.
5. Relax. Think about the comfort and energy savings you'll enjoy by using this helpful resource.



1. DIALING DOWN AND DRESSING UP

The easiest, least expensive way to increase the comfort of your home is to use your thermostat wisely and dress to make yourself comfortable.

The first part of the book explains how to use your thermostat for maximum comfort and lower energy costs; dress for comfort, whatever the weather outside; and adjust your lifestyle for maximum energy savings.

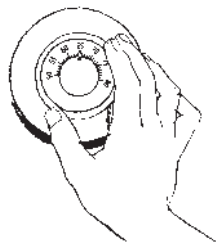

2. SEALING YOUR HOME

The cold blasts of winter and the heat waves of summer can greatly affect your comfort at home. While you can't control the weather, you can control the amount of heated or cooled air that enters and leaves your home. Sealing the air leaks in your home is one of the best ways to save energy – and money.

In section two, find out how to find and fix the air leaks by sealing doors, windows and other areas inside and outside your home. You'll find step-by-step instructions including lists of tools and materials you'll need to help increase your home's energy efficiency.

3. APPLIANCES

If you use your thermostat wisely and seal your home, you should enjoy greater comfort and increased energy savings. But you can also save energy by using home appliances wisely. The last part of this book explains how to get the most from your energy dollar through the efficient use of appliances.



4. NATURAL GAS: THE PREMIUM FUEL

Natural gas is a clean-burning, energy efficient and economical energy source. In section four you'll learn more facts about natural gas and its benefits for homeowners.

5. FOR MORE INFORMATION

We're easy to reach if you'd like to get other publications or tips on making your home more comfortable and energy efficient. In section five, you'll find out how to contact us by phone, mail or online.

1. DIALING DOWN & DRESSING UP

Dialing down your thermostat

Since 70 to 80 percent of your energy use is for heating, dialing down your thermostat is the easiest and most economical way to cut your energy costs. During the coldest winter months, you can save 5 to 10 percent on your fuel bill simply by lowering the thermostat five degrees for four or more hours each day. The greater the difference between the inside and outside temperatures, the faster your house will lose heat. Therefore, if you dial down your thermostat, your house will lose heat slower.



Programmable /setback thermostat

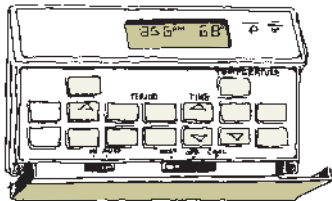

A programmable/setback thermostat saves energy by automatically adjusting the temperature setting in your home on a pre-set schedule. You can set the programmable/setback thermostat to lower the temperature at bedtime and to raise it shortly before you wake up. If no one is home all day, you might choose a double programmable/setback thermostat. This allows you to also lower and raise the temperature after you leave in the morning and before you return in the evening. The energy savings from using a programmable/setback thermostat will usually pay for the cost of the thermostat in one to two years.

Recommended thermostat settings

- The recommended thermostat setting in winter is 68 F while you're at home and 58 F while you're asleep or away from home for four or more hours.
- In the cooling season, the recommended setting for your thermostat is 15 F below the outside temperature. Never set it below 78 F.

Exceptions to recommended thermostat settings

Seniors, infants and people with certain medical conditions may need different temperature settings in order to avoid hypothermia or heat stress.

Hypothermia is a lowering of the body temperature below 95 F which causes the heart to slow down or stop beating.

During winter, room temperatures below 70 F might be too cold for some people and cause hypothermia.

Heat stress is an increase in the internal body temperature to an abnormally high temperature, possibly leading to heat exhaustion or heat stroke. During summer, heat stress can occur when temperatures stay 85 F or above.

Ask your doctor for recommended thermostat settings to avoid these health risks.



Keep warm in winter and cool in summer

You don't need to change the temperature setting on your thermostat to keep yourself comfortable. These steps will save energy and help you stay comfortable in any weather.

How to stay warm

- Wear several layers of medium-weight clothes rather than one heavy layer. Wool or wool blends are warmer than polyester knits. Stay warm indoors by wearing flannel shirts, sweaters, insulated underwear and socks. Surprisingly, if our hands and feet are cold indoors, wearing a scarf and hat will keep them warmer than wearing socks and mittens. The reason is simple: 40 percent or more of your body's heat is lost through your head and neck.
- Keep chairs away from cooler outside walls and windows so you won't be tempted to turn up the thermostat.
- Keep drapes, furniture, and floor coverings from blocking heat and cold air return registers, radiators or space heaters.
- Open window coverings on the sunny side of your home. Let the sunlight give you "free heat." Close window coverings on cloudy days or as soon as the sun sets.
- Close your fireplace damper when the fireplace is not in use.
- Eat nutritious foods and drink warm, non-alcoholic beverages.



- Tighter sealing of your home, with adequate ventilation, can eliminate the need to add humidity by preventing warm, moist air from escaping through cracks. Too much humidity in your home in cold weather can cause serious damage to walls and windows. It can also cause mold to grow, which can be a health hazard for you and your family. If you have questions about the correct humidity level for your home, call us at the number on page 50.
- Use your bathroom fan when showering or bathing. Use your kitchen fan when cooking.
- Use several light blankets to trap warm air – this will give more comfort than one heavy cover.

WARNING: Do not use your gas oven as an extra heater. Doing so can be dangerous.

How to stay cool

- Wear light, loose-fitting clothes made of fabrics that "breathe." Cotton is cooler than synthetic fabrics like nylon and polyester.
- Create breezes through your home by opening 25 percent more windows on the downwind or hot side of the house than on the upwind or cool side.
- Avoid using your air conditioner unnecessarily. A fan uses very little electricity compared to an air conditioner.
- To cool a single room have a fan draw cool outside air into the room at night.
- Close window coverings on the sunny side of your home to keep out heat from the sun.





- Avoid causing unnecessary heat and humidity indoors. Schedule chores such as baking, clothes drying, ironing, and dishwashing in the early morning or late evening hours. Use kitchen and bathroom exhaust fans to remove moisture and heat from the air. Avoid extra humidity by hanging wet clothes outside. Cook summer meals on top of the range, not in the oven. Better yet, cook outdoors on a grill.

- Take cool showers or baths to reduce your body temperature and help avoid heat stress. Water will absorb your body's heat better than air.
- Get plenty of rest and sleep. You can handle the discomfort better if you're well rested.
- Avoid heavy meals and drink plenty of cool liquids. Water or non-alcoholic beverages are best. Avoid stimulants such as coffee or tea.

2. SEALING YOUR HOME

Why sealing your home can save you money

There are many cracks and gaps around your doors and windows and throughout your home. In the heating season, these openings let warm air leak out and cold air leak in. In the cooling season, they let cool air out and



hot humid air in. Homeowners and renters are often unaware of the many spaces where treated air can escape.

- If you add together all the small cracks and gaps in your home, you might find they equal the size of a 2 by 2-foot hole in your wall.
- A leaky home can cost up to 40 percent more to heat or cool.

Sealing your home is economical because the materials cost relatively little. Homeowners can do most sealing themselves by getting the materials at a hardware store and by following the directions given on the package or in this book.

Sealing the inside of your home first is the best method to use. You can seal inside during any time of the year. And sealing from the inside will keep as much heat as possible exactly where you want it – inside in winter and outside in summer. The best place to start is in the attic or upper floors.

Sealing the attic

When sealing air leaks in your home it is important to start in the attic or upper level. Because warm air rises, it moves into the attic during cold weather. Air leaks in the attic are known as attic bypasses. They can cut the effectiveness of attic insulation by 30 to 70 percent, can allow moisture to enter the attic where it can damage ceiling and insulation and cause ice dams on the roof.

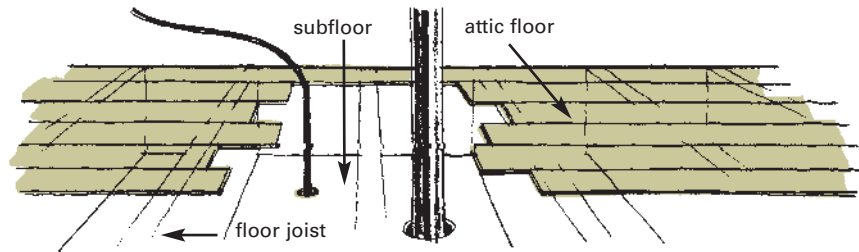

- Caulk small openings in the attic subfloor where pipes, wires, etc. enter the attic. For larger gaps use stuffing material such as void filler or unfaced fiberglass insulation. (Before using either of these materials, see pages 33-34.)
- Seal the gap around your metal flue or masonry chimney with a metal flue collar or with sheet metal. You can purchase the necessary materials at a hardware store. You'll need roofing nails and tin snips to complete the project. Also buy heat-resistant caulk to seal the edges of the metal flue collar or sheet metal.
- Caulk around the attic door (or trap) frame where it meets the wall or ceiling. Weather-strip and insulate the door (or trap), too. Use vinyl V-strip for your attic door or foam weather-stripping for your trap door (see page 34).

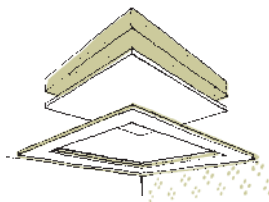
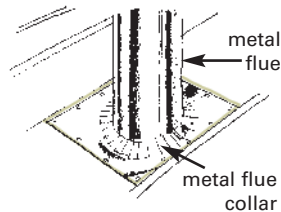

- Seal the tops of the walls at each end of your attic by stuffing insulation into them. Also stuff insulation into the tops of any walls (such as a bathroom wall near the plumbing vent) that are not blocked off by a board.
- If you have an expansion attic as shown on the right, stuff insulation into the area between the bottom of the kneewall and the attic subfloor.
- You may find openings over dropped ceilings above kitchens, bathrooms and closets. Nail a sheet of plastic over these openings at the attic subfloor level. Seal the edges of the plastic sheet with caulk.

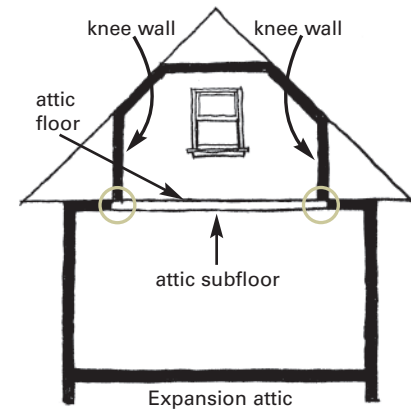

NOTE:

- Recessed lights, especially older ones, can leak air from your home into the attic. They can also be a fire hazard in insulated ceilings. Do not try to insulate or build an enclosure over recessed lights without first having them checked by an electrical inspector.
- If you have an unfloored attic, walk on the floor joists or lay a board over the joists as shown above.
- Do not seal roof vents or any other ventilation openings from the attic to the outside.

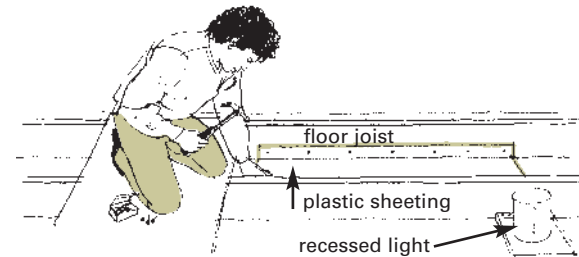

Sealing doors

Doors leading to the outside or to any unheated area (such as a porch or attic) should be sealed to reduce cold drafts and heat loss.

Weatherstripping doors

Weatherstripping is the material used to fill the gap between the door and the door frame so less air leaks in and out. You may already have weatherstripping on your door frame. If you can feel cold air coming in, the weatherstripping needs to be repaired or replaced.

A common type of weatherstripping is called V-strip. When V-strip is put on the door frame, the V widens to fill the gap between the door frame and the door.

If you already have metal V-strip on your door frame, check to see if the V looks flattened or if the metal looks dull. The metal should be shiny from rubbing against the door. If it looks flattened or dull, use a putty knife or screwdriver to widen the V so it fills the gap between the door and the door frame.

If the metal has no spring left, you should replace it. For a temporary solution, vinyl V-strip, which has a sticky backing on one side, is an option. It works like the metal V-strip but it's relatively inexpensive and easier to apply. Vinyl V-strip is available at most hardware stores.

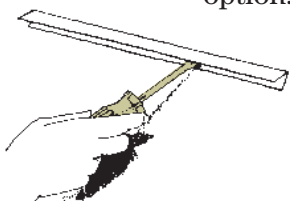

How to weatherstrip a door with vinyl V-strip

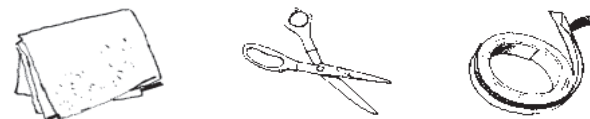

Materials for weatherstripping a door with vinyl V-strip include: a damp rag, scissors, and about 17 feet of vinyl V-strip weatherstripping.

1. Clean the door frame with a damp rag. Allow it to dry.
2. Hold the weatherstripping up to the door frame to measure it. Using scissors, cut the vinyl V-strip into three sections – one to fit each side of the door frame and one to fit the top.
3. Fold each strip in half along the pre-scored center with the paper backing facing out.
4. You will need to trim the ends of the V-strip that will meet at the corners of the door frame (see illustration). Using scissors, cut the non-sticky backed side of the V-strip at a 45-degree angle. This angle will allow the two non-sticky backed sides of the V-strip to meet at the corner without overlapping.
5. Peel the paper off the sticky backing.

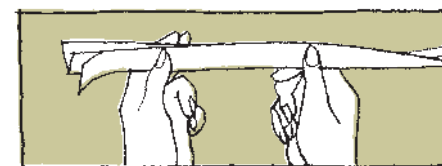

6. Put the weatherstripping on the door frame close to the doorstop so the door presses against the V-strip when closed. The creased side of the V should face in for doors that open in and face out for doors that open out. Wherever possible, put the weatherstripping along the entire length of the door in one piece.

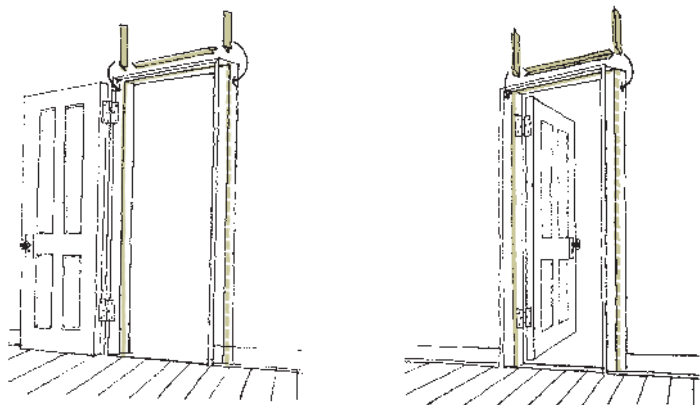

7. After you have finished applying the V-strip, make sure the door closes tightly and there is no air leaking at the corners of the door or at the lock plate.

Doorsweeps

A doorsweep is a strip of material fastened to the bottom of your door. It helps stop air from leaking in and out of your home. A metal doorsweep with three pieces of rubber at the bottom of your door is one of the best types. If you cannot screw a metal doorsweep onto your door, there are sticky back types which only need to be cut and pressed into place.

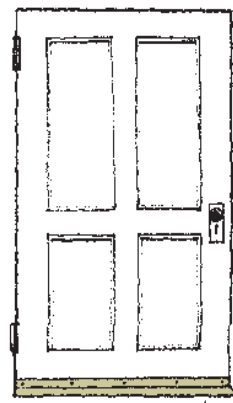
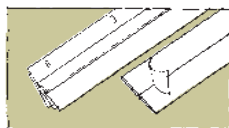

Doorsweep

How to put on a metal doorsweep

Materials for putting on a metal doorsweep include: a hacksaw, scissors, a screwdriver, and a file.

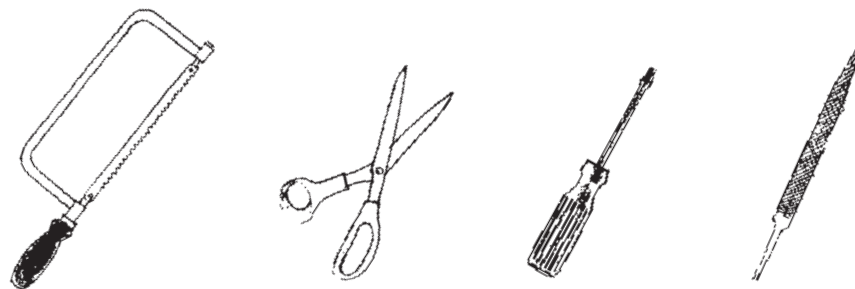

1. Put the doorsweep on the outside of a door that opens out and on the inside of a door that opens in.
2. Hold the doorsweep against the door, centering it so a screw hole is very close to each edge of the door. Make sure the doorsweep covers the entire width of the door.
3. Use a pencil to mark the door where the screw hole will be. Draw lines on the doorsweep to mark the edges of the door.

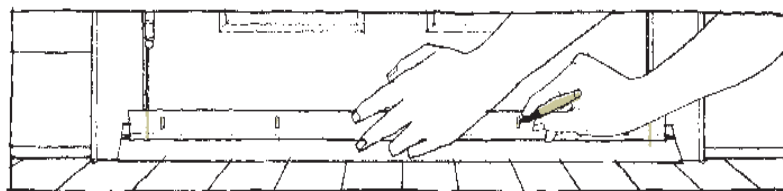

4. Slide the rubber piece away from the end of the doorsweep. Use a hacksaw to cut through the metal. Make the cuts on the pencil lines that you drew in step 3. You may want to file down the rough edges so they aren't sharp.

NOTE: Be careful not to bend the doorsweep as you saw it. Work on a flat surface.

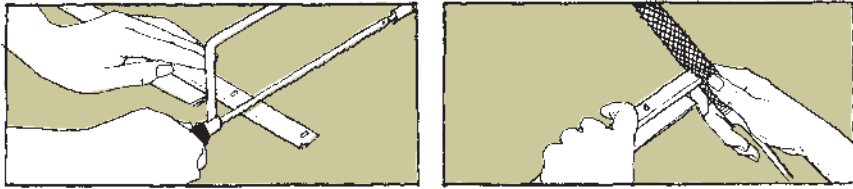

5. Slide the rubber piece back into place. On the edge of the door nearest to the doorknob, cut the rubber at an angle so it extends beyond the edge of the door. The angled piece of rubber will help block air leaks at the corner of the door. On the hinged edge of the door, cut the rubber straight so the door can be opened and closed freely.
6. If the door you are putting the doorsweep on is made of solid wood or metal, you might have to drill holes for the screws.
7. Hold the doorsweep against the bottom of the door so the doorsweep touches the floor, and put the screws halfway in, but do not tighten them yet.

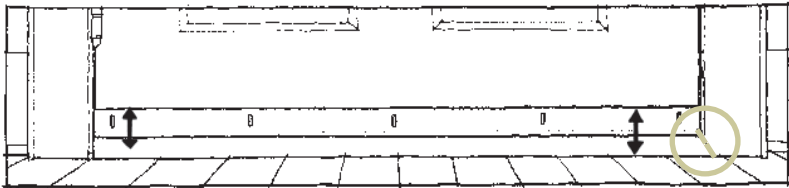

NOTE: The screw holes on the doorsweep are shaped to adjust the doorsweep up or down.

8. With the screws halfway in, adjust the doorsweep to make certain the door opens freely and the doorsweep covers the space between the door and the floor or threshold.
9. Tighten the screws.

Caulking doors

Air can leak into your home where the door frame meets the inside wall and where the threshold meets the floor. Caulk is the material used to fill a crack or hole so less air leaks in and out. Use caulk to seal any cracks around the frame of the door. (For information on how to caulk, see pages 31-33.)

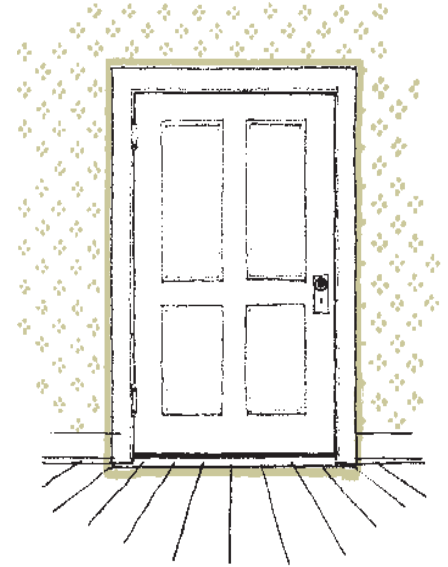

Other ideas for doors

- A door held open for just a few seconds lets in a lot of cold or warm air. Say your “hellos” and “goodbyes” behind closed doors!
- Use tape or rope caulk (see page 29) to seal unused keyholes on doors that lead to the outside or to unheated areas.
- Keep doors to the outside and to unheated areas firmly closed. Teach your children to close doors too.



Sealing windows

In winter, you may feel chilled when you stand near a window, or you may see frost on the inside of a storm window. This means cold air is leaking in and warm moist air is leaking out. By sealing windows, you can reduce air leaks and cut energy costs.

There are three basic types of windows:

- **Sliding windows** move from side to side in the window frame.
- **Casement windows** swing open and shut on hinges.
- **Double hung windows** slide windows up and down. They are the most common type of window found in older homes.

What type of windows do you have?

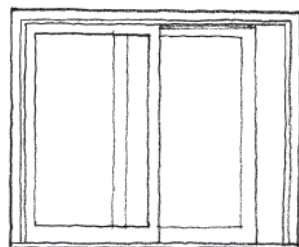

Sliding window

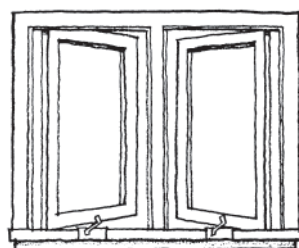

Casement window

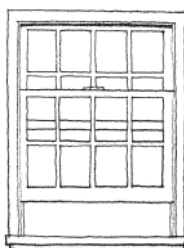

Double hung window

Using caulk to seal windows and window frames

Whatever type of windows you have, you can seal them with rope caulk or a clear removable caulk. Put the caulk into the areas where the window meets the window frame. If you have sliding windows or double hung windows, make sure to put caulk into the areas where the two windows meet in the middle. (For information on caulk, see pages 29-33).

Whatever method you use to seal the movable parts of your windows, you should also make sure to caulk any joints or cracks on the window frame itself and where the window frame meets the inside wall. Don't forget the top and bottom of the window frame.

Weatherstripping windows

If you have casement windows or double hung windows, weatherstripping them with vinyl V-strip is an option. Unlike removable caulks, weatherstripping allows you to open and close your windows without first removing the sealing material.

Note: Vinyl V-strip is a quick, inexpensive treatment but is temporary and works best in areas that are rarely used.

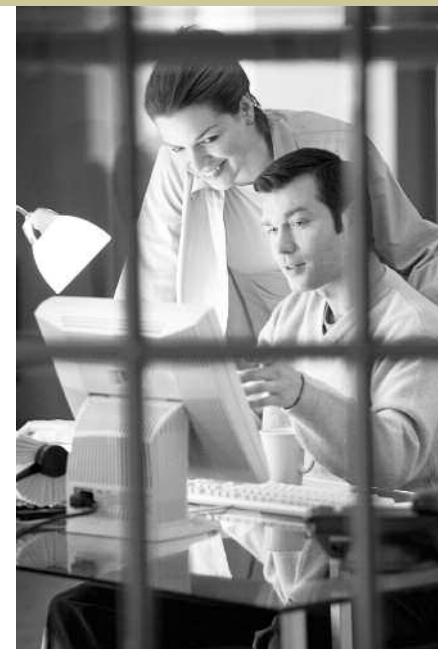

How to weatherstrip a double-hung window with vinyl V-strip

Materials for weatherstripping a double-hung window with vinyl V-strip include: a damp rag, scissors, and about 12 feet of vinyl V-strip.

1. Clean the window frame with a damp rag. Allow it to dry.
2. Cut four pieces of vinyl V-strip – one for the bottom of the window, one for the sash where the top and bottom windows meet, and one for each side of the bottom window. Cut the pieces for the two sides a few inches longer than the height of the bottom window. This will keep the edge of the V-strip from catching when you move the window up and down.
3. Fold the strips in half with the paper backing facing out.
4. Peel the paper off the V-strip for the bottom of the window. Stick the strip on the bottom of the window sash with the creased part of the V facing in.
5. Peel the paper off the V-strip that will fit where the top and bottom windows meet. Raise the bottom window a few inches so you can reach behind the top of it. Stick the V-strip to the back of the middle sash. The creased part of the V should face down.

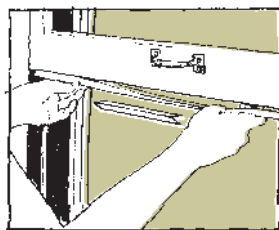
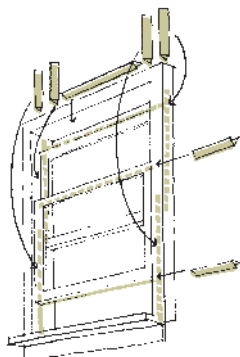
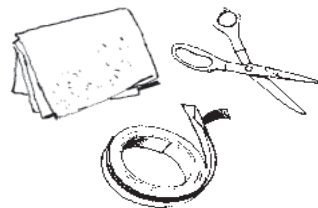

6. Raise the bottom window all the way up. Peel the paper off the strip that will go on the side of the window. Leave an extra few inches of the paper at the top of the strip, so you can slide the strip up past the middle sash. Then slide the papered part of the V-strip up the side of the window past the middle sash. Stick the weatherstripping onto the channel. The creased part of the V should face in.
7. Once the V-strip is in place, lower the window all the way and peel off the paper at the top of the strip. Then press the extra inches into place.
8. Repeat steps 6 and 7 for the other side of the window.
9. If your top window slides down, cut three pieces of V-strip. Put them on the two sides and the top of the window.
10. Check to make sure the window opens and closes easily and no air leaks through the moving parts of the windows.

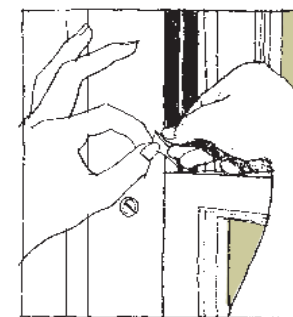
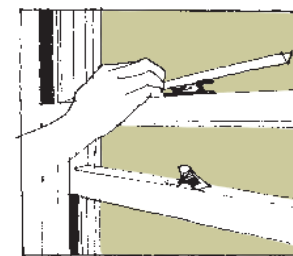

How to weatherstrip a casement window with vinyl V-strip

You can weatherstrip casement windows with vinyl V-strip – just as you would weatherstrip a door (see pages 13-15). Note that you will need a fourth piece of vinyl V-strip for the bottom of the window.

Using window coverings to help seal windows

Windows are the coldest surfaces in most homes. Warm ceiling air moves down the windows and back into your room as cold air. You can avoid this if your window coverings fit tightly on all four sides. You can use heavy drapes, plastic, or insulated shades or inserts to cover your windows. Remember, however, that sealing the window first with weatherstripping and caulk will improve the efficiency of any window covering. Window coverings installed over leaky or inefficient windows can cause ice to form on windows.

Hang heavy or lined drapes so they rest on the windowsill or hang all the way to the floor. Use safety pins to pin the drapes together in the center, tape them to the walls at the sides, and place a box valance at the top. If you have shades, pull them down so they rest on the windowsill. Be sure your drapes do not cover heat and cold air return registers, radiators or space heaters.

Another way to cover your window is to attach plastic over the window and window frame on the inside of your home. You can use clear plastic sheets and tacks. Or you can apply a heat-sensitive plastic film using tape and a hair dryer. However, do not use window coverings as a “cure” for condensation problems. The best way to reduce condensation is to reduce the sources of moisture and to run bathroom and kitchen exhaust fans while bathing or cooking.

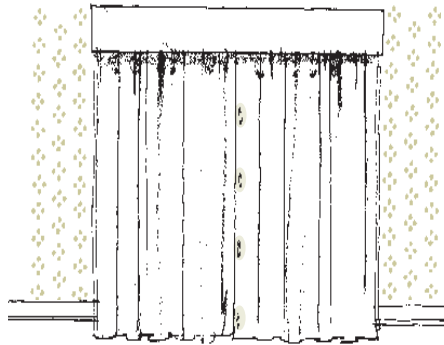
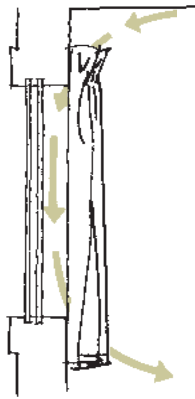

There are many kinds of insulated shades or inserts to choose from. When you shop for insulated window coverings, look for these features:

- ease of use
- fire resistant material
- high R-value (resistance to heat loss)
- tight edge seals
- a vapor barrier

Note: As you read about window coverings and water heater blankets (see page 38), you will see the term “R-value.” R-value means resistance to heat loss. The higher the R-value, the more resistant the material is to heat loss. Building materials like glass and wood have low R-values; insulating materials like polyester fill and fiberglass have high R-values. Be sure to ask your salesperson about the R-value of any insulating material you buy.

Other ideas for windows

- Replace or repair the glass on a broken or cracked window. To repair, use glazing tape or freezer tape. Both are available at your hardware store. Clear nail polish spread on the crack also works.
- Lock your windows for a better seal against air leaks. Be sure storm windows are also shut tightly.
- Your windowpanes should fit tightly in place. If they are loose, you need to putty them. Window putty (commonly called glazing compound) is available at your hardware store.
- Open window coverings on the sunny side of your home to let sunlight warm your home in winter. Close them on cloudy days or as soon as the sun sets.

- Close window coverings to keep out heat from the sun in summer.
- Cover the pulley holes on your double hung windows in one of the following ways:

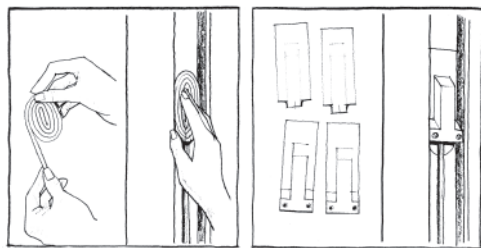

- Use rope caulk to form a patty. Press the patty over the entire pulley opening (see page 29).
- Or use permanent pulley seals that allow the window to open and close. These are available at your hardware store.

Sealing the basement

- Caulk cracks between the window frame and foundation.
- Caulk openings in the basement ceiling around pipes, wires, etc. For larger gaps, use stuffing materials such as void filler or unfaced fiberglass insulation (see pages 33-34).
- Seal the gap around the metal flue or masonry chimney with a metal flue collar or with sheet metal. You can purchase the necessary materials at a hardware store. You'll need roofing nails and tin snips to complete the project. Also buy heat-resistant caulk. You'll need it to seal the edges of the metal flue collar or sheet metal. Do not allow insulation to contact the metal flue.

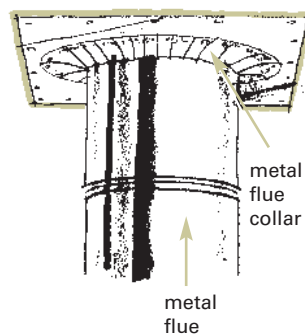
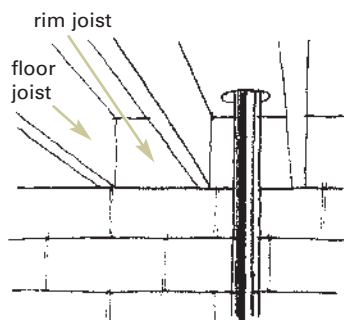

- Caulk where the dryer vent meets the outside wall or rim joist (the board that sits on top of the foundation).
- Caulk cracks in the rim joist.
- Caulk the top and bottom of the rim joist (where it meets the floor above it and the foundation).
- Caulk cracks in the foundation.
- Seal any openings at the top of the foundation blocks.

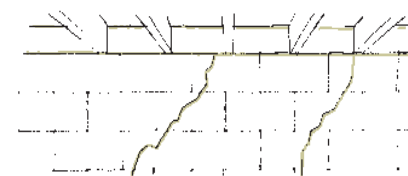
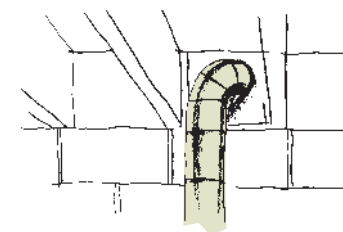

Sealing other areas on the inside of your home

- Buy foam gaskets at the hardware store and put them behind your electrical outlet and light switch plates. Put the removable inserts of the electrical outlet gaskets behind your safety caps. The safety caps can be put into unused electrical outlets to plug air leaks.
- Caulk the cracks where the basement meets the wall and floor.

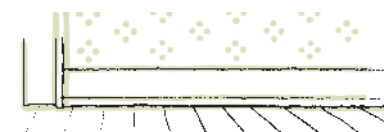
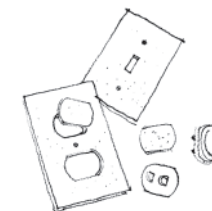

- Caulk around your window wall air conditioner.
- On kitchen and bathroom fans, caulk the enclosure to the ceiling and frame.
- Caulk around pipes and electrical conduits that go through the ceiling.
- Seal cracks and plug holes in your walls.
- Caulk the cracks around pipes from a sink or toilet that go through the wall.
- If you use your fireplace, close the damper tightly when it's not in use.
- Caulk where the fireplace meets the wall.

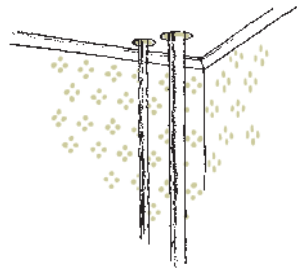
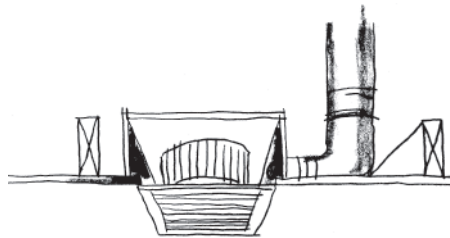
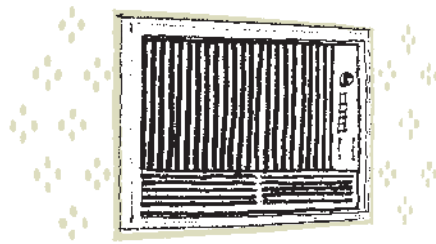

Sealing the outside of your home

- Caulk the tops of windows and doors (drip caps) next to siding.
- Caulk where the window and door frames meet the siding.
- Caulk any openings for utility outlets, outside faucets, vents, fans, or anything else that enters your home through the outside wall.
- Caulk where the siding meets at the corners of the house.
- Caulk the gap between the foundation and the house.
- Caulk where storm windows meet the window frame, except for the small drain holes at the bottom of the storm window. If you plan to remove your storm windows in summer, use weather-stripping or removable caulk – not permanent caulk. If you never plan to remove your storm windows, permanent caulk is best.



Caulk and other sealing materials

Before you buy materials for sealing your home, consider which materials and how much of each you will need, their cost, and how easy they will be to install.



Caulk

For most of the cracks and gaps in your home, caulk will be the best sealer. When you buy caulk, remember, the cheapest isn't always the best. Always read the label of the caulk carefully and consider where you will be putting it. If you use it on the chimney, on heating ducts, or on any other heat-producing surface, be sure it can withstand temperatures up to 400 F. If you want to paint over the caulk, be sure the label says it is paintable. Also be sure to buy caulk that will stick to the surface where you plan to use it.

Types of caulk – removable

The following caulks can be left in place or removed:

- **Rope caulk** is like children's modeling clay. You can press it into the gaps around windows or into hard-to-reach places where a tube of caulk won't fit. If it is still clean and flexible when you remove it, you can store it in a plastic bag for later use.
- **Press-in-place caulk** comes pre-shaped and sticks to most surfaces. You can use it where permanent tube caulk is used. It will last for up to 20 years. Once removed, it cannot be reused.

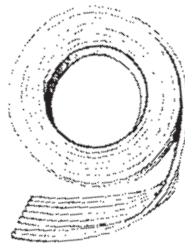

Rope caulk

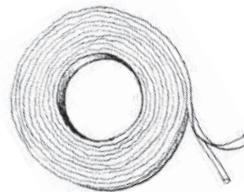

Press-in-place caulk

- **Clear removable caulk** comes in a pressurized tube or in a tube for use with a caulk gun. Use it where you would use permanent caulk and leave it in place, or use it around windows and remove it at any time. Once removed, it cannot be reused.

Types of caulk – permanent

The following caulks come in a tube. You will need a caulk gun to apply most caulks. Ask your salesperson for a demonstration of how to operate a caulk gun or see pages 31-33.

Latex/acrylic caulk

- lower priced
- lasts approximately 2 to 5 years
- paintable
- forms a hard surface when dry
- cleans up with water
- more suitable for indoor use
- available in white and other colors
- not suitable for heat-producing surfaces

Siliconized latex/acrylic caulk

- medium priced
- lasts approximately 20 years
- paintable
- cleans up with water
- slight flexibility when dry
- average resistance to moisture
- available in clear, white and other colors
- not suitable for heat-producing surfaces
- suitable for indoor and outdoor use

Silicone caulk

- higher priced
- usually not paintable
- good flexibility when dry
- higher resistance to moisture
- suitable for heat-producing surfaces only if rated to 400 F
- available in clear, white and other colors
- suitable for indoor and outdoor use
- lasts approximately 20 years
- solvent needed for clean-up

How to caulk with a caulk gun

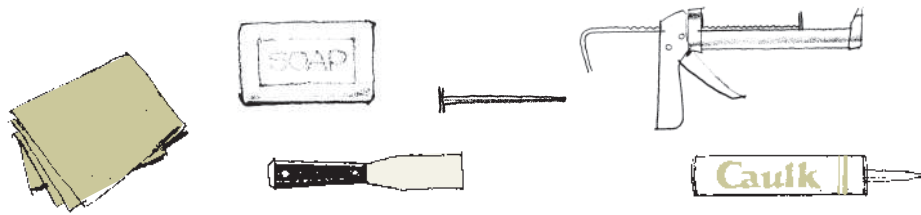

Materials for caulking with a caulk gun include: a damp rag, a bar of soap, a putty knife, a nail, a caulk gun, and a tube of caulk.

1. Use a putty knife to remove dirt, loose paint and old caulk. Then clean the surface with a damp rag to make sure the new caulk can stick. Allow it to dry.
2. Turn the plunger rod of the caulk gun so the teeth face up. Pull the rod out as far as it will go.

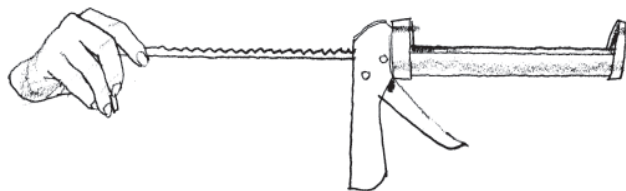

3. Place the tube of caulk into the caulk gun.

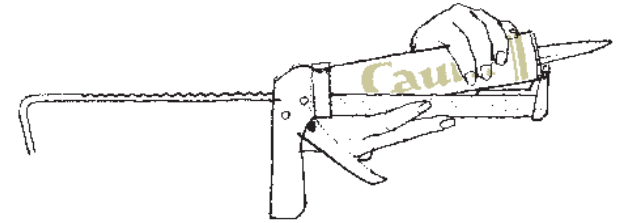

4. Turn the plunger rod so the teeth face down. Push the plunger back in, up against the bottom of the tube of caulk, until the teeth catch on the caulk gun.

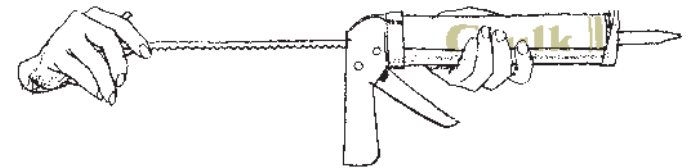

5. Cut off the tip of the tube at about a 45° angle. The nozzle is tapered so the amount of the tip you cut off will determine whether you have a thin or thick bead of caulk.

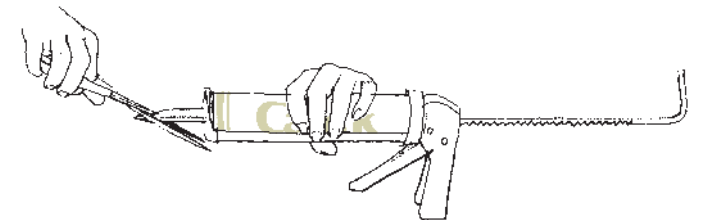

6. Use a long nail to break the seal inside the caulk tube (and to plug the nozzle when you want to store leftover caulk).

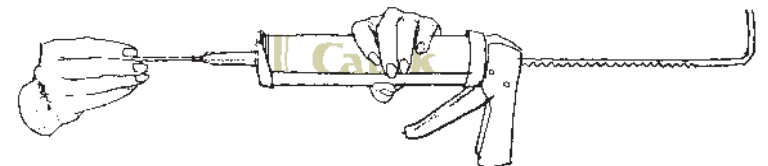

7. Hold the caulk gun at a 45-degree angle to the surface and pull the trigger, keeping a steady pressure on it.

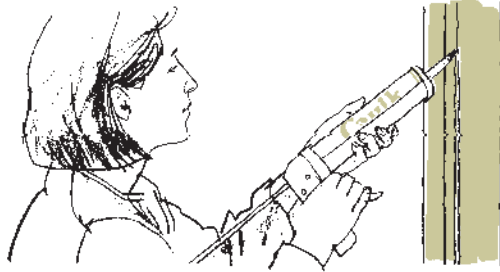

8. Push the gun away from you in order to push the caulk into the crack. Try to finish a seam in one stroke without stopping.
9. Make sure the caulk covers both sides of the crack. This will give you a good seal.

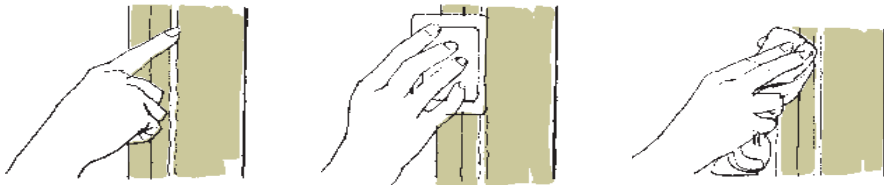

10. If the label recommends smoothing the caulk, use a wet finger (watch out for splinters) or the edge of a bar of soap.
11. Wipe off any excess caulk with a wet rag.
12. Practice caulking in areas that won't show, such as the top of window frames or in the attic.

Other materials for sealing

- **Void filler** is used for large, even cracks. It is a rod-shaped spongy material that comes in 3/8-inch, 1/2-inch and 5/8-inch diameters. Put the void filler snugly into the crack and caulk over it making

sure that the caulk seals the crack from edge to edge. Do not use void filler around heat-producing surfaces.

- **Unfaced fiberglass insulation** is a fluffy material that is normally used for insulating. It can also be used to seal gaps that are too large for caulking or that are unevenly shaped. Tightly roll the fiberglass and stuff it snugly into the top of the gap. Always wear gloves and a dust mask when using fiberglass.

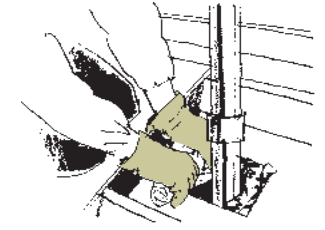
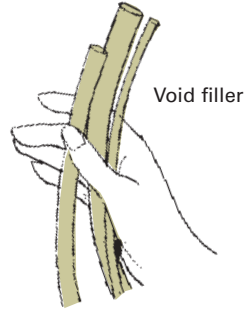

- **Foam weatherstripping** is a spongy strip of material with sticky backing on one side. Use it mainly to seal where one surface presses against another, such as an attic trap door. It is best suited for areas that are rarely used.

Foam weatherstripping



- **A metal flue collar** is used to seal the gap around your metal flue. **Sheet metal** is used to seal the gap around your masonry chimney. You will need roofing nails and tin snips to install these materials. You can purchase the materials at your hardware store. Also, buy heat-resistant caulk. You'll need it to seal the edges of the metal flue collar or sheet metal.

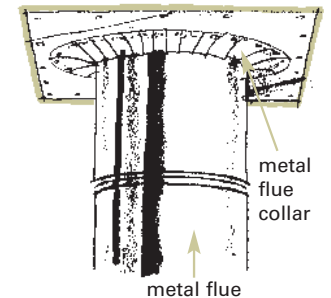

3. APPLIANCES

Your heating system probably accounts for more than 70 percent of your energy use, your water heater for more than 15 percent. Using these and other appliances wisely can cut your energy costs.

Anytime you are considering purchasing a new appliance, consider an energy-efficient ENERGY STAR® qualified model. See page 47.

Heating system

- Keep heat and cold air return registers free of dust and do not block with carpet or furniture so warm air can flow freely.
- Clogged furnace filters on forced air systems cut heat flow and make furnaces run longer. Clean or change the filters regularly (once a month is recommended during the heating season).
- Place materials that reflect, like aluminum foil, behind radiators with the shiny side toward the room to send heat back into the room. To work best, there should be a gap between the wall and the material. Setting things on top of or in front of radiators will slow the flow of heat into the room.
- Bleed radiators as necessary. It will keep your heating system working more efficiently.

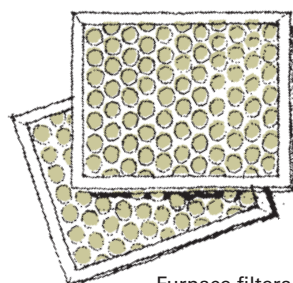

Furnace filters

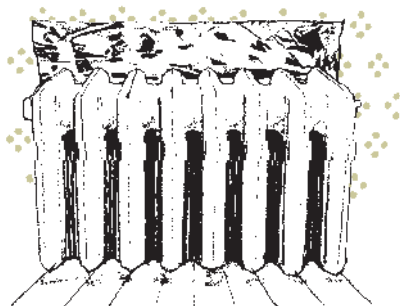

- Install plastic deflectors on warm air registers that are located near windows. This will help direct warm air into the room.



- Use duct sealant or foil duct tape to seal air leaks in heating ducts that run through unheated areas of your home.
- Make sure any water pipes in these areas won't freeze by installing pipe insulation.

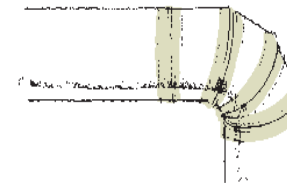

Cooling system

- Install your window air conditioner on the north or shady side of the house.
- Seal gaps around the air conditioner to keep summer heat from entering and winter warmth from leaving your home.
- In the fall, use an air conditioner cover and/or styrofoam insulation to cover the outside of the unit. This will prevent heat from escaping through the unit during the winter months.
- Change or clean filters when dirty.
- If you can, vacuum the coils and cooling fins on the outside of the air conditioner.

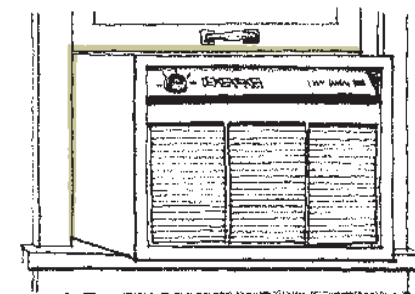

Note: Be sure to turn off your air conditioner before cleaning it.

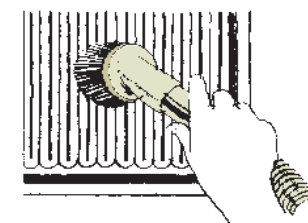

- Keep drapes or furniture away from your air conditioner, allowing the air to flow freely.
- Avoid cooling an empty house. Install a programmable/setback thermostat for central air conditioners or a timer designed for room air conditioners.
- Avoid cooling rooms that you don't use often.
- Use extra fans to improve the circulation of your air conditioner.

Water heater and hot water pipes

- Repair leaky hot water faucets. A leak that fills a coffee cup in ten minutes wastes 3,280 gallons of water in a year. The cost of heating this water is over \$15 per year.
- Turn down the temperature setting on your water heater. Doing so is one of the best ways to cut energy costs. Hot water can cause serious scalding, especially to small children and the elderly. To reduce the danger, set the water heater temperature at 120 F or less. On most water heaters, that will be the "low" setting on the water heater thermostat. You can also measure the water temperature at a faucet with a thermometer. Whenever you are away for vacations, turn the temperature control to the lowest setting.
- Wrap your water heater. If your water heater is in an unheated area, you may want to wrap it with a water heater blanket. Water heater blankets are relatively inexpensive, easy to install, and available at most hardware stores.

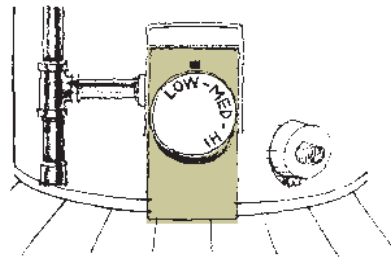

A blanket with an R-value (resistance to heat loss) of R-6 is your best value. Follow these guidelines for wrapping your gas water heater. Water heaters in a heated area will not benefit substantially from a water heater blanket.

- Follow the manufacturer's installation instructions.
- Do not cover the top of the water heater.
- Trim the bottom of the water heater blanket so it does not cover any part of the door that leads to the burner.
- Trim the blanket around the temperature control dial.
- Tape down all edges.
- Wrap your hot water pipes. If your water heater is located in a heated area, wrap the hot water pipe leading away from it for about ten feet. In an unheated area, wrap the entire length of any hot water pipes. Preformed foam pipe wrap comes in various pipe sizes. It is available at most hardware stores, and is easy to install.

Note: As a safety precaution, keep the pipe wrap 6 inches away from the gas water heater flue.



This space must be at least 6".

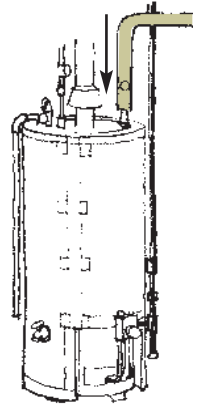

- Reduce hot water use by doing the following:

- A short shower uses about half as much hot water as the average tub bath. Limit shower time and use an energy-saving, low-flow shower head, or install a flow restrictor. These items are available at most hardware stores.
- Many laundry detergents can be used in cold water, and you can always use cold water for rinsing. Use warm water only when necessary.
- Run the dishwasher only when you have a full load.
- Use a dishpan to wash dishes if doing them by hand. Don't leave the hot water running.
- Install an aerator on the end of your kitchen faucet. Doing so will reduce your hot water use by as much as 50 percent.
- Don't run hot water while shaving or brushing your teeth.

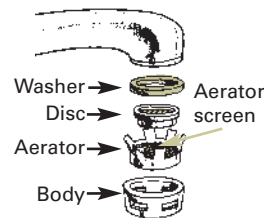

Kitchen range

Range top

- Whenever possible, save energy by using the range top rather than the oven.
- Select the right pan size for the amount of food you're cooking. Keep the flame centered under the pan so the flame does not curl around the side of the pan.
- Clean the reflector pans under the burners regularly. Clean reflectors help focus heat.
- Keep the bottoms of your pots clean and shiny. Shiny pots help focus heat better than dull, soiled pots do.
- Thaw frozen foods in the refrigerator before cooking them. Doing so will save energy and help reduce the risk of food poisoning.
- Cook with covers on pots and pans whenever possible.
- Limit the amount of water used for cooking. When food begins to boil, lower the flame to maintain a gentle boil or simmer. Food doesn't cook any faster with a rolling boil.

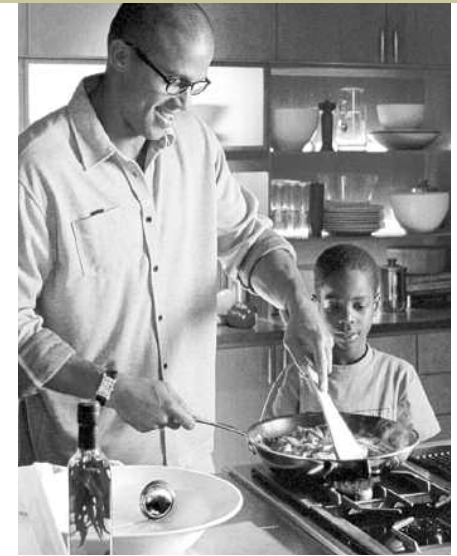

Oven

- Cook as many things as possible at one time.
- Bake more than one recipe and freeze the extra for later use.
- Try not to peek. Opening the oven door can reduce the temperature by as much as 50 F.
- Just before food has finished cooking, turn off the oven. The heat inside will finish the cooking.
- Most foods don't need a preheated oven. For breads and baked goods, preheat for about 7 minutes with the oven setting at the exact temperature required for baking.
- Broilers do not require preheating. Keep the door closed while broiling.
- Never use aluminum foil to line the bottom of the oven. It could block vents, reducing air circulation and oven temperatures. If you wish, line the oven rack with foil, leaving a 1-inch space on all sides.

WARNING: Do not turn on your gas oven and open the door to heat a room. When used for normal cooking, oven burners cycle on and off. If you leave the door open even a little with the oven on, the burner will run continuously. This can cause carbon monoxide to build up, which can be a threat to your health.

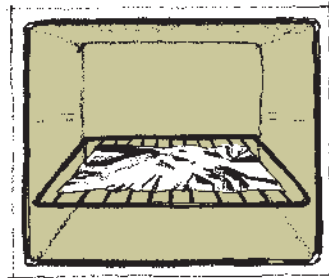
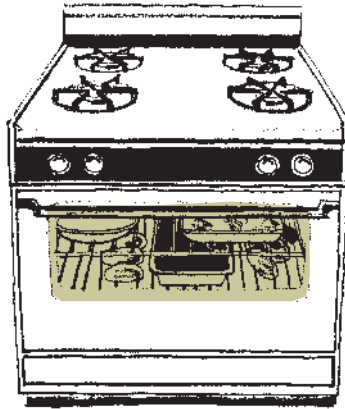

Clothes washer

- Wash full loads of clothes. A half load uses almost as much energy as a full load. Match wash time, cycle and water level to the clothes load.
- Follow detergent instructions carefully.
- Presoak stained clothing so that you can shorten the wash cycle.

Clothes dryer

- Vent your clothes dryer to the outside. This will prevent combustion products, excess moisture, and small bits of detergent and lint from entering your home.
- Check outside to make sure your dryer vent flap is clear of lint so it can close tightly when the dryer is off.
- Clean the dryer lint screen before each load. A clogged lint screen slows down the circulation of warm air and increases drying time.
- If your dryer has an electronic sensor or an automatic drying control, use it instead of timed drying. This will help you avoid overdrying. Overdrying wastes energy and causes clothes to wrinkle and wear out faster.
- Separate clothes by weight. Lightweight fabrics require less drying time.
- Dry full loads but don't overload. Excessively large loads take longer and use more energy.
- Whenever possible, dry several loads one after another. It takes less energy to bring the dryer to the required temperature each time.

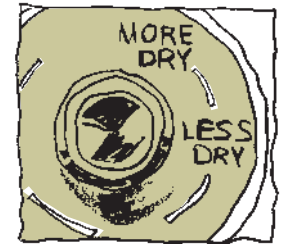
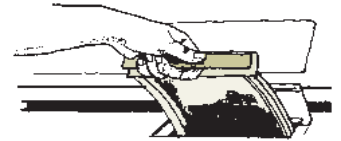

Refrigerator/freezer

- Keep your refrigerator and freezer full to avoid letting warm air enter when you open the doors. Bottles of water in the refrigerator and ice cubes in the freezer reduce the amount of air space. Remember, it takes more energy to keep air cold than to keep food cold. Don't pack your refrigerator or freezer too full, though. Some air needs to circulate to keep the food cold.
- Open the refrigerator or freezer door only when necessary and for as short a time as possible.
- Allow space around the outside of the refrigerator for good air circulation.
- Cover liquids. Uncovered liquids add humidity to the refrigerator and make it work longer.
- Defrost frozen food in the refrigerator. The frozen food will help cool the refrigerator and save energy.
- Keep the refrigerator running efficiently by cleaning the condenser coils occasionally. The condenser coils are located at the back or bottom of the refrigerator.



NOTE: Be sure to unplug the refrigerator before you vacuum or clean the condenser coils.

- Defrost the freezer before ice builds up to 1/4-inch thick. Ice on the freezer wall insulates the compartment from the cooling element, making the unit run longer.
- Keep your refrigerator between 37 F and 40 F and your freezer at about 0 F. If the dial reads "Hi, Medium, Low," test the temperature with an outdoor or refrigerator thermometer. Cold milk and frozen ice cream are also good indicators.
- Keep the seals (gaskets) of the doors clean and replace them if necessary.
- Some refrigerators have an anti-sweat heater designed to keep the walls on the outside of the refrigerator dry during humid weather. Since you won't need it most of the year, turn off the heater (the switch is inside the refrigerator). If the switch says "power-miser" or "energy-saver" turn the switch on to turn the heater off. If it says "dry/humid" make sure it is set on "dry." When moisture appears on the outside of the refrigerator, turn on the heater until the humid weather is over.

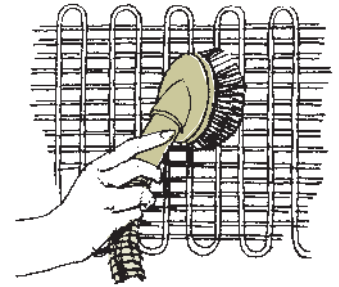

Dishwasher

- Run the dishwasher only when it is full.
- Scrape rather than rinse dishes before loading them. If rinsing is required, use a dishpan and cold water.
- If your dishwasher has a filter, check it often to be sure it isn't clogged with food.
- Open the dishwasher door prior to the drying cycle to let the dishes air dry.
- Use the proper amount of detergent. Too much or too little detergent will reduce cleaning efficiency.
- If you have a choice, use a shorter cycle with fewer fills of water.
- Follow the manufacturer's loading suggestions for the greatest efficiency.
- When shopping for a dishwasher, look for an energy efficient model that has a water temperature booster. This heats water right at the dishwasher and allows you to keep your water heater setting lower – at 120 F instead of 140 F.

Other energy users in your home

- Always turn off lights, TV sets, VCRs, DVD players and radios when rooms are vacant. These appliances also generate unwanted heat in the summer.
- If you have an “instant-on” TV, unplug it when you go away for the weekend or on vacation. This type of TV uses energy whenever it's plugged in.
- Limit the use of portable heaters to temporary heating – only when someone is in the room.
- Use cold water rather than hot water to operate your food disposal. Grease becomes solid in cold water and will move through pipes easier. Grease in hot water sticks to the cold surfaces of pipes.
- Empty vacuum cleaner bags frequently to increase vacuum cleaner efficiency. Change disposable bags before they get too full.



4. NATURAL GAS: THE PREMIUM FUEL

- Concentrate lighting in reading and working areas and where it's needed for safety. When possible, replace bulbs with bulbs of the next lower wattage. However, for areas that need a great deal of light, one large wattage bulb will give more light than several smaller wattage bulbs. Dirt absorbs light, so keep lamps and bulbs clean.



- Consider using traditional or compact fluorescent light bulbs in kitchens, bathrooms and work areas. They are four times more efficient than incandescent bulbs.
- Consider using dimmers or high /low switches. They save energy.
- When buying an appliance, remember that it has two price tags: what you pay to take it home and what you pay for the energy and water it uses.
 - Look for the yellow EnergyGuide label found on most appliances. This label allows you to compare the yearly operating costs of different models.
 - Look for appliances and electronics with the ENERGY STAR® label. ENERGY STAR qualified appliances incorporate advanced technologies that use 10 to 15 percent less energy and water than standard models. The money you save on your utility bills can more than make up for the cost of a more expensive but more efficient ENERGY STAR model. To find out which products qualify, or for more information, visit www.energystar.gov or call 1-888-STAR-YES.

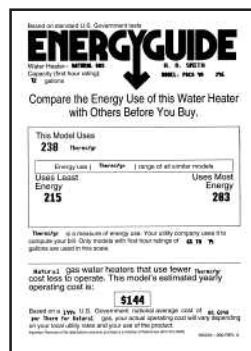

Natural gas has many advantages over other energy forms used in American homes. Nearly all of the natural gas we use in the United States – 99 percent – comes from North America, and supplies are abundant. CenterPoint Energy does not need to rely on supplies from overseas; natural gas is efficiently transported from North American gas fields to your home by pipeline.



There is no need to store supplies of natural gas at your home as you would need to, for example, for wood, coal or oil. And you don't have to pay for the gas until after you've used it. Natural gas burns cleanly and completely – it produces no smoke or ash that can cause health hazards, acid rain, or other environmental problems.

This premium fuel also remains the least expensive energy for most homes. CenterPoint Energy believes natural gas is, and will remain, your best energy value. Use it wisely.

5. FOR MORE INFORMATION

Thank you for reading **More Comfort, Less Energy**. We hope you enjoyed it and will use the ideas to improve your comfort at home and to reduce the amount of energy you use.

If you have any questions about the information covered here, about other methods of making your home more energy efficient, or about CenterPoint Energy, please contact us.

CenterPoint Energy offers a variety of energy conservation programs and free publications to help you with questions about natural gas, wise energy use, appliances, and more. Specially trained representatives are available to answer your questions Monday through Friday between 7 a.m. and 6 p.m.



Contact us

Visit our Web site at **CenterPointEnergy.com**. Select your region from the drop-down menu next to *Residential*. Click on *Customer Service* and then on *Contact Us*.

Call 612-372-4727 or 1-800-245-2377

Or write
CenterPoint Energy
Energy Answers
PO Box 59038
Minneapolis, MN 55459-0038